

Marvell Plug Computing Development Kit

Always-on Computing for the Digital Home



▶ PRODUCT OVERVIEW

Marvell®'s Plug Computer is an embedded computer that plugs into the wall socket and can run network-based services that normally require a dedicated personal computer. Featuring a Marvell ARM-based CPU running up to 2GHz CPU with 512MB of Flash memory and 512MB of DDR2 memory, the Plug Computer provides ample processing power and resources to run any embedded computing application. Network connectivity is via Gigabit Ethernet; peripheral devices can be connected using USB 2.0, and in some versions of the kits also can connect via WiFi, or Bluetooth interface. Software for the Plug Computer includes multiple Linux distributions and follows the open-source model, making the Plug Computer an ideal platform on which to develop or port any application. The Plug Computer development kit contains the Plug Computer as well as all of the software tools needed to develop applications for the platform.



Fig 1. Plug Computer Development Kit

▶ KEY FEATURES AND BENEFITS

FEATURES	BENEFITS
<ul style="list-style-type: none"> • End-product form factor 	<ul style="list-style-type: none"> • Professional demonstration of new applications • Suitable for initial trials • Shorter time to production
<ul style="list-style-type: none"> • Open platform 	<ul style="list-style-type: none"> • Available at low cost to any interested developer • Readily available Linux distributions • Community support
<ul style="list-style-type: none"> • High performance with low power 	<ul style="list-style-type: none"> • Ideal for always-on computing tasks • Easier to port existing software without modification • Run multiple applications concurrently
<ul style="list-style-type: none"> • GHz class processor 	<ul style="list-style-type: none"> • Wirespeed packet processing • Fast response for interactive applications • High speed access to USB 2.0 connected storage
<ul style="list-style-type: none"> • Built-in debug support 	<ul style="list-style-type: none"> • Direct connect to a PC via mini USB cable • JTAG access • Serial console interface
<ul style="list-style-type: none"> • Wide range of I/O Interface 	<ul style="list-style-type: none"> • Gigabit Ethernet Interface for fast wirespeed access to Broadband connection • USB 2.0 interface to large variety of peripherals such as USB HDD • WiFi/BT interface to remote end points • Provision to include HDD

▶ APPLICATIONS

In the plug computing model, network-based software services that are normally run from a desktop or laptop computer are instead delivered from a more efficient device that can be left on all of the time at 10 percent of the cost. Basic examples of network-based services include Web, email, and virtual private networks that are run on servers hosted in homes and small offices. A rapid increase in the amount and variety of digital content and network-connected devices in the home is creating even more opportunities, as increasing numbers of software services are needed to locate, manage, secure, and share this data.

Unlike Web 2.0 hosted services that use central servers on the Internet to store copies of data, the plug computing approach distributes computing power to every home. A plug computer can take advantage of peer-to-peer connectivity over the Internet, as well as the latest network protocols—such as Universal Plug and Play (UPnP)—that only work between devices in the home. In some scenarios, a hybrid approach, which combines hosted services with an in-home computing resource, can reduce deployment costs and make services easier to use.

Developers can create native applications for the Plug Computer on the open-source Linux platform. Marvell also has created RainDrop, an open-source API framework that makes it effortless to deploy third-party applications onto the Plug Computer securely and in a resource-defined manner. Finally, the Plug Computer supports a Java Virtual Machine and an OSGI stack, allowing for the rapid deployment of third-party OSGI services.

DIAGRAMS

Development Kit	CPU Speed	Gigabit Ethernet	USB 2.0	WiFi/ BT	SATA
Plug Computer 1.0	1.2GHz	✓	✓		
Plug Computer 2.0	1.2GHz	✓	✓	✓	
Plug Computer 3.0	2.0GHz	✓	✓	✓	✓

Fig 2. Comparison Chart

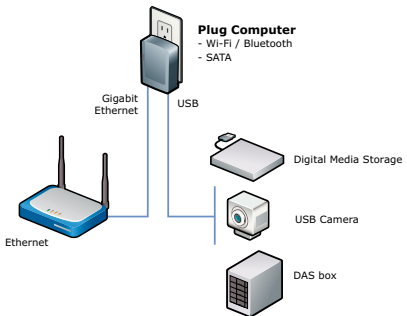

Fig 3. Installation Diagram

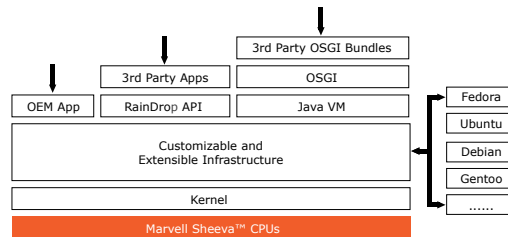

Fig 5. Software Development Diagram

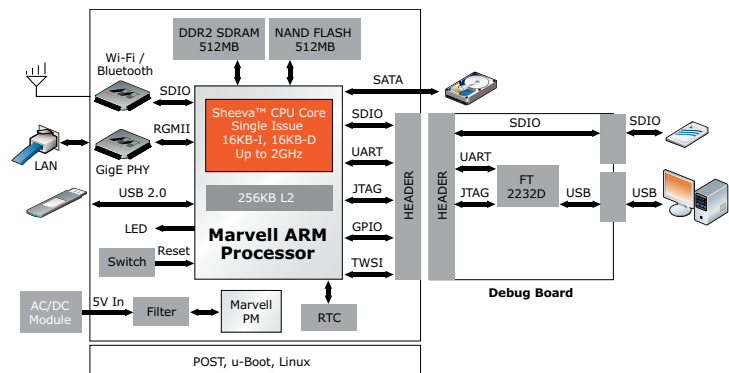

Fig 4. Block Diagram

PACKAGE CONTENTS

Plug Computer, USB cable, ethernet cable, CD containing software and documentation.

THE MARVELL ADVANTAGE: Marvell chipsets come with complete reference designs which include board layout designs, software, manufacturing diagnostic tools, documentation, and other items to assist customers with product evaluation and production. Marvell's worldwide field application engineers collaborate closely with end customers to develop and deliver new leading-edge products for quick time-to-market. Marvell utilizes world-leading semiconductor foundry and packaging services to reliably deliver high-volume and low-cost total solutions.

ABOUT MARVELL: Marvell is a leader in storage, communications, and consumer silicon solutions. Marvell's diverse product portfolio includes switching, transceiver, communications controller, processor, wireless, power management, and storage solutions that power the entire communications infrastructure, including enterprise, metro, home, storage, and digital entertainment solutions. For more information, visit our Web site at www.marvell.com.



Marvell Semiconductor, Inc.
5488 Marvell Lane
Santa Clara, CA 95054
Phone 408.222.2500
www.marvell.com

Copyright © 2010. Marvell International Ltd. All rights reserved. Marvell, Moving Forward Faster, the Marvell logo, Alaska, AnyVoltage, DSP Switcher, Fastwriter, Feroceon, Libertas, Link Street, PHYAdvantage, Prestera, TopDog, Virtual Cable Tester, Yukon, and ZJ are registered trademarks of Marvell or its affiliates. Armada, CarrierSpan, LinkCrypt, Marvell Smart, PowerSmart PFC, Powered by Marvell Green PFC, Qdeo, QuietVideo, Sheeva, TwinD, and VCT are trademarks of Marvell or its affiliate. All other trademarks are the property of their respective owners.
PlugComputer_DevKit-01 1/10