



88E3016

Integrated 10/100 Fast Ethernet Transceiver



Doc. No. MV-S103164-00, Rev. A

January 4, 2008

Document Classification: Proprietary Information

| Document Status | |
|-------------------------|---|
| Advance Information | This document contains design specifications for initial product development. Specifications may change without notice. Contact Marvell Field Application Engineers for more information. |
| Preliminary Information | This document contains preliminary data, and a revision of this document will be published at a later date. Specifications may change without notice. Contact Marvell Field Application Engineers for more information. |
| Final Information | This document contains specifications on a product that is in final release. Specifications may change without notice. Contact Marvell Field Application Engineers for more information. |
| Revision Code: Rev. A | |
| Advance | Technical Publication: 1.10 |

Document Conventions

| | |
|---|--|
|  | Note: Provides related information or information of special importance. |
|  | Caution: Indicates potential damage to hardware or software, or loss of data. |
|  | Warning: Indicates a risk of personal injury. |

For more information, visit our website at: www.marvell.com

Disclaimer

No part of this document may be reproduced or transmitted in any form or by any means, electronic or mechanical, including photocopying and recording, for any purpose, without the express written permission of Marvell. Marvell retains the right to make changes to this document at any time, without notice. Marvell makes no warranty of any kind, expressed or implied, with regard to any information contained in this document, including, but not limited to, the implied warranties of merchantability or fitness for any particular purpose. Further, Marvell does not warrant the accuracy or completeness of the information, text, graphics, or other items contained within this document. Marvell products are not designed for use in life-support equipment or applications that would cause a life-threatening situation if any such products failed. Do not use Marvell products in these types of equipment or applications.

With respect to the products described herein, the user or recipient, in the absence of appropriate U.S. government authorization, agrees:

- 1) Not to re-export or release any such information consisting of technology, software or source code controlled for national security reasons by the U.S. Export Control Regulations ("EAR"), to a national of EAR Country Groups D:1 or E:2;
- 2) Not to export the direct product of such technology or such software, to EAR Country Groups D:1 or E:2, if such technology or software and direct products thereof are controlled for national security reasons by the EAR; and,
- 3) In the case of technology controlled for national security reasons under the EAR where the direct product of the technology is a complete plant or component of a plant, not to export to EAR Country Groups D:1 or E:2 the direct product of the plant or major component thereof, if such direct product is controlled for national security reasons by the EAR, or is subject to controls under the U.S. Munitions List ("USML").

At all times hereunder, the recipient of any such information agrees that they shall be deemed to have manually signed this document in connection with their receipt of any such information.

Copyright © 2008, Marvell International Ltd. All rights reserved. Marvell, the Marvell logo, Moving Forward Faster, Alaska, Fastwriter, Datacom Systems on Silicon, Libertas, Link Street, NetGX, PHYAdvantage, Prestera, Raising The Technology Bar, The Technology Within, Virtual Cable Tester, and Yukon are registered trademarks of Marvell. Ants, AnyVoltage, Discovery, DSP Switcher, Feroceon, GalNet, GalTis, Horizon, Marvell Makes It All Possible, RADLAN, UniMAC, and VCT are trademarks of Marvell. All other trademarks are the property of their respective owners.



OVERVIEW

The Marvell® 88E3016 device is the fourth generation Marvell® DSP-based physical layer transceiver for Fast Ethernet applications. The device contains all the active circuitry to convert data streams to and from a Media Access Controller (MAC) and the physical media. The 88E3016 device incorporates IEEE 802.3u Auto-Negotiation in support of both 100BASE-TX and 10BASE-T networks over twisted-pair cable in full-duplex or half-duplex mode.

The 88E3016 device supports the Reduced Gigabit Media Independent Interface (RGMI).

The 88E3016 device features a mode of operation supporting IEEE compliant 100BASE-FX fiber-optic networks. Additionally, the 88E3016 device implements Far-End Fault Indication (FEFI) in order to provide a mechanism for transferring information from the local station to the link partner that indicates a remote fault has occurred in 100BASE-FX mode.

The 88E3016 device features the Marvell Virtual Cable Tester® (VCT™) technology, which enables IT managers and networking equipment manufacturers to remotely analyze the quality and characteristics of the attached cable plant.

The 88E3016 device uses advanced mixed-signal processing and power management techniques for extremely low power dissipation and high port count system integration. The 88E3016 device is manufactured in an all CMOS process and packaged in a 64-pin QFN package.

FEATURES

- IEEE 802.3 compliant 100BASE-TX and 10BASE-T ports
- Reduced Gigabit Media Independent Interface (RGMI)
- Virtual Cable Tester® (VCT™) Technology
- PECL interface supporting 100BASE-FX applications
- Automatic MDI/MDIX crossover for 10BASE-T and 100BASE-TX
- Jumbo frame support to 10 Kbytes with up to ±150 ppm clock frequency difference
- IEEE 802.3u Auto-Negotiation support for automatic speed and duplex selection
- Far-End Fault Indication (FEFI) support for 100BASE-FX applications
- Supports 802.3ah Unidirectional Enable
- Energy detect feature
- Baseline wander correction
- Auto-Calibration for MAC Interface outputs
- COMA Mode support
- Flexible serial management interface (MDC/MDIO) for register access
- Programmable interrupt to minimize polling
- IEEE 1149.1 Standard Test Access Port and boundary scan compatible
- Supports three (3) LEDs per port
- 0.15 μm standard digital CMOS process
- 64-pin QFN 9 mm x 9 mm package

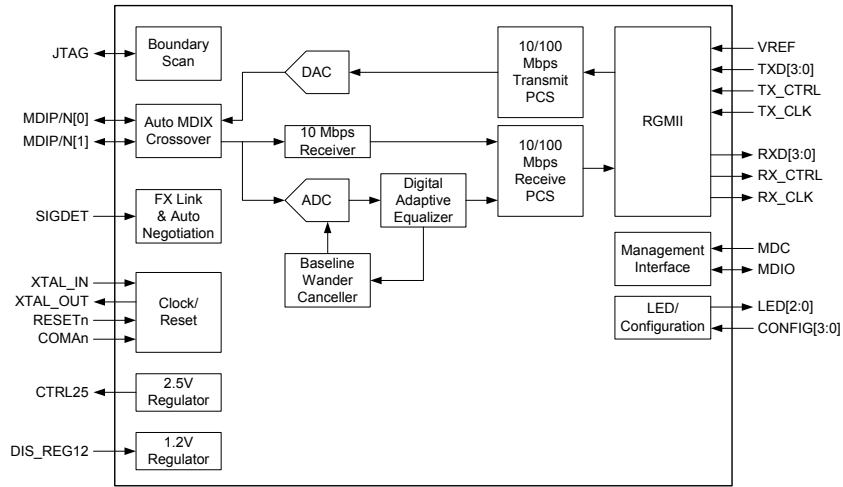

88E3016 Device Functional Block Diagram

Table of Contents

| | |
|--|-----------|
| SECTION 1. SIGNAL DESCRIPTION | 8 |
| 1.1 88E3016 Device 64-Pin QFN Pinout | 8 |
| 1.2 Pin Description..... | 9 |
| 1.2.1 Pin Type Definitions | 9 |
| 1.2.2 88E3016 64-Pin QFN Assignments - Alphabetical by Signal Name | 16 |
| SECTION 2. FUNCTIONAL DESCRIPTION..... | 17 |
| 2.1 Reduced Gigabit Media Independent Interface (RGMI) | 18 |
| 2.2 Serial Management Interface | 19 |
| 2.2.1 MDC/MDIO Read and Write Operations | 19 |
| 2.2.2 Preamble Suppression | 20 |
| 2.2.3 Programming Interrupts..... | 20 |
| 2.3 Transmit and Receive Functions..... | 21 |
| 2.3.1 Transmit Side Network Interface | 21 |
| 2.3.2 Encoder | 21 |
| 2.3.3 Receive Side Network Interface | 21 |
| 2.3.4 Decoder..... | 22 |
| 2.3.5 Auto-Negotiation..... | 23 |
| 2.4 Power Management | 24 |
| 2.4.1 IEEE Power Down Mode | 24 |
| 2.4.2 Energy Detect +TM | 24 |
| 2.4.3 Normal 10/100 Mbps Operation | 24 |
| 2.4.4 COMA Mode..... | 25 |
| 2.5 Regulators and Power Supplies | 26 |
| 2.5.1 AVDD | 26 |
| 2.5.2 AVDDC..... | 26 |
| 2.5.3 AVDDR..... | 26 |
| 2.5.4 AVDDX..... | 27 |
| 2.5.5 DVDD | 27 |
| 2.5.6 VDDO | 27 |
| 2.5.7 VDDOR | 27 |
| 2.6 Hardware Configuration | 28 |
| 2.7 Far End Fault Indication (FEFI)..... | 30 |
| 2.8 802.3ah Unidirectional Enable | 30 |
| 2.9 Virtual Cable Tester® Feature..... | 31 |
| 2.10 Auto MDI/MDIX Crossover | 32 |



| | |
|---|-----------|
| 2.11 LED Interface | 33 |
| 2.11.1 Manual Override | 33 |
| 2.11.2 PHY Control..... | 34 |
| 2.11.3 LED Polarity..... | 38 |
| 2.11.4 Stretching and Blinking..... | 38 |
| 2.12 Automatic and Manual Impedance Calibration..... | 39 |
| 2.12.1 MAC Interface Calibration Circuit | 39 |
| 2.12.2 MAC Interface Calibration Register Definitions | 39 |
| 2.12.3 Changing Auto Calibration Targets | 40 |
| 2.12.4 Manual Settings to The Calibration Registers | 40 |
| 2.13 CRC Error Counter | 44 |
| 2.13.1 Enabling The CRC Error Counter..... | 44 |
| 2.14 IEEE 1149.1 Controller | 45 |
| 2.14.1 Bypass Instruction | 45 |
| 2.14.2 Sample/Preload Instruction | 45 |
| 2.14.3 Extest Instruction | 46 |
| 2.14.4 The Clamp Instruction | 47 |
| 2.14.5 The HIGH-Z Instruction | 47 |
| 2.14.6 ID CODE Instruction | 47 |
| SECTION 3. REGISTER DESCRIPTION..... | 48 |
| SECTION 4. ELECTRICAL SPECIFICATIONS..... | 78 |
| 4.1. Absolute Maximum Ratings | 78 |
| 4.2. Recommended Operating Conditions | 79 |
| 4.3 Package Thermal Information | 80 |
| 4.3.1 88E3016 Device 64-Pin QFN package..... | 80 |
| 4.4 Current Consumption | 81 |
| 4.4.1 Current Consumption AVDD + Center Tap | 81 |
| 4.4.2 Current Consumption AVDDC..... | 81 |
| 4.4.3 Current Consumption DVDD | 82 |
| 4.4.4 Current Consumption VDDO + VDDOR..... | 82 |
| 4.5. DC Operating Conditions..... | 83 |
| 4.5.1 Non-RGMII Digital Pins | 83 |
| 4.5.2 Stub-Series Transceiver Logic (SSTL_2)..... | 84 |
| 4.5.3 IEEE DC Transceiver Parameters..... | 86 |
| 4.6 AC Electrical Specifications | 87 |
| 4.6.1 Reset and Configuration Timing | 87 |
| 4.6.2 XTAL_IN Input Clock Timing | 88 |
| 4.7 RGMII Interface Timing | 89 |
| 4.7.1 RGMII Transmit Timing | 89 |
| 4.7.2 RGMII Receive Timing | 90 |

| | | |
|---|---|------------|
| 4.8 | Latency Timing | 92 |
| 4.8.1 | RGMII to 100BASE-TX Transmit Latency Timing | 92 |
| 4.8.2 | RGMII to 10BASE-T Transmit Latency Timing..... | 92 |
| 4.8.3 | 100BASE-TX to RGMII Receive Latency Timing | 93 |
| 4.8.4 | 10BASE-T to RGMII Receive Latency Timing..... | 93 |
| 4.9 | Serial Management Timing | 94 |
| 4.10 | JTAG Timing | 95 |
| SECTION 5. PACKAGE MECHANICAL DIMENSIONS | | 96 |
| 5.1 | 88E3016 Package Mechanical Dimensions | 96 |
| SECTION 6. APPLICATION EXAMPLES | | 98 |
| 6.1 | 10BASE-T/100BASE-TX Circuit Application | 98 |
| 6.2 | FX Interface to 3.3V Fiber Transceiver | 99 |
| 6.3 | Transmitter - Receiver Diagram | 100 |
| 6.4 | 88E3016 to 88E3016 Backplane Connection - 100BASE-FX Interface | 101 |
| 6.5 | 88E3016 to Another Vendor's PHY - 100BASE-FX Interface through a Backplane | 102 |
| 6.6 | Marvell® PHY to Marvell PHY Direct Connection | 103 |
| SECTION 7. ORDER INFORMATION | | 104 |
| 7.1 | Ordering Part Numbers and Package Markings | 104 |

Section 1. Signal Description

1.1 88E3016 Device 64-Pin QFN Pinout

The 88E3016 is manufactured in a 64-pin QFN.

Figure 1: 88E3016 Integrated 10BASE-T/100BASE-TX Fast Ethernet Transceiver 64-Pin QFN Package

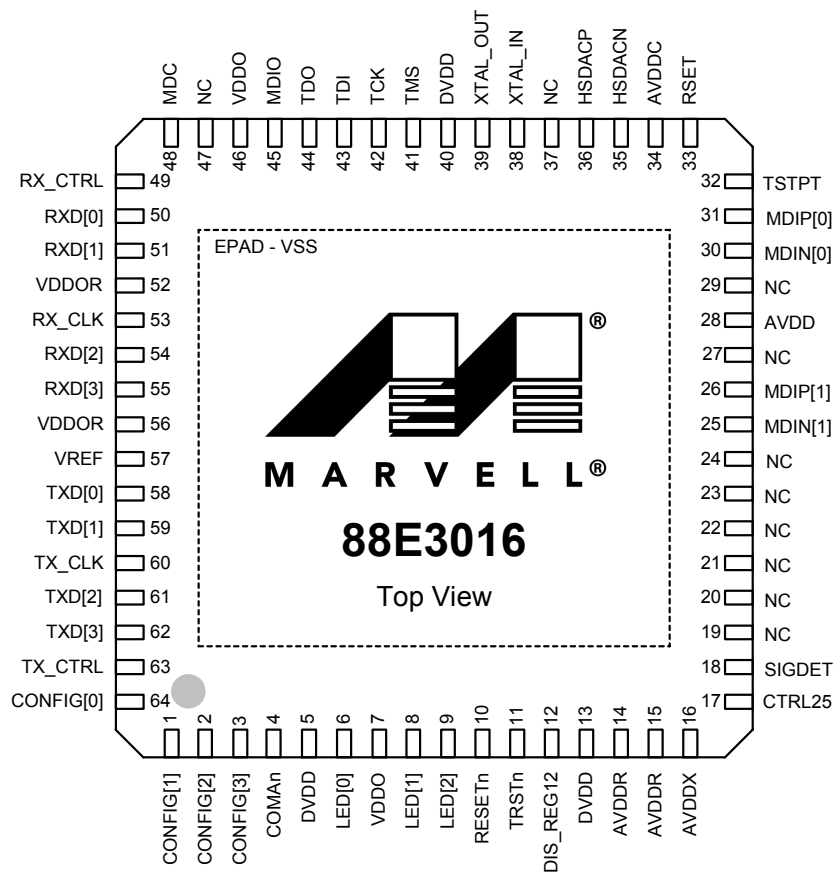

1.2 Pin Description

1.2.1 Pin Type Definitions

| Pin Type | Definition |
|----------|-----------------------|
| H | Input with hysteresis |
| I/O | Input and output |
| I | Input only |
| O | Output only |
| PU | Internal pull up |
| PD | Internal pull down |
| D | Open drain output |
| Z | Tri-state output |
| mA | DC sink capability |

Table 1: RGMII Interface

| 88E3016 | Pin Name | Type | Description |
|----------------------|--|-------------|---|
| 60 | TX_CLK/TXC | I | RGMII Transmit Clock provides a 25 MHz or 2.5 MHz reference clock with ± 50 ppm tolerance depending on speed. In RGMII mode, TX_CLK is used as TXC. |
| 63 | TX_CTRL/TX_CTL | I | RGMII Transmit Control. TX_EN is presented on the rising edge of TX_CLK. In RGMII mode, TX_CTRL is used as TX_CTL. A logical derivative of TX_EN and TX_ER is presented on the falling edge of TX_CLK. |
| 62 61 59 58 | TXD[3]/TD[3] TXD[2]/TD[2] TXD[1]/TD[1] TXD[0]/TD[0] | I | RGMII Transmit Data. In RGMII mode, TXD[3:0] are used as TD[3:0]. The transmit data nibble is presented on TXD[3:0] on the rising edge of TX_CLK. |
| 53 | RX_CLK/RXC | O | RGMII Receive Clock provides a 25 MHz or 2.5 MHz reference clock with ± 50 ppm tolerance derived from the received data stream depending on speed. In RGMII mode, RX_CLK is used as RXC. |
| 49 | RX_CTRL/ RX_CTL | O | RGMII Receive Control. RX_DV is presented on the rising edge of RX_CLK. In RGMII mode, RX_CTRL is used as RX_CTL. A logical derivative of RX_DV and RX_ER is presented on the falling edge of RX_CLK. |
| 55 54 51 50 | RXD[3]/RD[3] RXD[2]/RD[2] RXD[1]/RD[1] RXD[0]/RD[0] | O | RGMII Receive Data. In RGMII mode, RXD[3:0] are used as RD[3:0]. The receive data nibble is presented on RXD[3:0] on the rising edge of RX_CLK. |

Table 2: Network Interface

| 88E3016 | Pin Name | Type | Description |
|----------|--------------------|------|--|
| 31 30 | MDIP[0] MDIN[0] | I/O | Media Dependent Interface[0]. In MDI configuration, MDI[0]± is used for the transmit pair. In MDIX configuration, MDI[0]± is used for the receive pair. |
| 26 25 | MDIP[1] MDIN[1] | I/O | Media Dependent Interface[1]. In MDI configuration, MDI[1]± is used for the receive pair. In MDIX configuration, MDI[1]± is used for the transmit pair. |
| 18 | SIGDET | I | In 100BASE-FX mode, SIGDET indicates whether a signal is detected by the fiber optic transceiver. In 100BASE-TX/10BASE-T modes, this pin should not be left floating. It should be tied either high or low. |

Table 3: Serial Management Interface

| 88E3016 | Pin Name | Type | Description |
|---------|----------|------|--|
| 48 | MDC | I | MDC is the clock reference for the serial management interface. A continuous clock stream is not required (i.e., MDC can be stopped when the MDC/MDIO master is not sending a command). The maximum frequency supported is 8.33 MHz. |
| 45 | MDIO | I/O | MDIO is the management data. MDIO is used to transfer management data in and out of the device synchronously to MDC. This pin requires a pull-up resistor in a range from 1.5 kohm to 10 kohm. |

Table 4: LED

| 88E3016 | Pin Name | Type | Description |
|---------|------------------|------|---|
| 9 | LED[2]/Interrupt | O | Parallel LED outputs. See Section 2.11 "LED Interface" on page 33 for LED interface details. See Section 2.2.3 "Programming Interrupts" on page 20 for interrupt details. |
| 8 | LED[1] | O | Parallel LED outputs. See Section 2.11 "LED Interface" on page 33 for LED interface details. |
| 6 | LED[0] | O | Parallel LED outputs. See Section 2.11 "LED Interface" on page 33 for LED interface details. |

Table 5: JTAG

| 88E3016 | Pin Name | Type | Description |
|---------|----------|------|---|
| 43 | TDI | I | Boundary scan test data input. TDI contains an internal 150 kohm pull-up resistor. |
| 41 | TMS | I | Boundary scan test mode select input. TMS contains an internal 150 kohm pull-up resistor. |
| 42 | TCK | I | Boundary scan test clock input. TCK contains an internal 150 kohm pull-up resistor. |
| 11 | TRSTn | I | Boundary scan test reset input. Active low. TRSTn contains an internal 150 kohm pull-up resistor as per the 1149.1 specification. After power up, the JTAG state machine should be reset by applying a low signal on this pin, or by keeping TMS high and applying 5 TCK pulses, or by pulling this pin low by a 4.7 kohm resistor. |
| 44 | TDO | O | Boundary scan test data output. |

Table 6: Clock/Configuration/Reset

| 88E3016 | Pin Name | Type | Description |
|-------------------|--|------|---|
| 38 | XTAL_IN | I | Reference Clock. 25 MHz \pm 50 ppm tolerance crystal reference or oscillator input. |
| 39 | XTAL_OUT | O | Reference Clock. 25 MHz \pm 50 ppm tolerance crystal reference. When the XTAL_OUT pin is not connected, it should be left floating. XTAL_OUT is used for crystal only. This pin should be left floating when an oscillator input is connected to XTAL_IN. |
| 3 2 1 64 | CONFIG[3] CONFIG[2] CONFIG[1] CONFIG[0] | I | Hardware Configuration. See "Hardware Configuration" on page 28. |
| 10 | RESETn | I | Hardware reset. Active low. XTAL_IN/XTAL_OUT must be active for a minimum of 10 clock cycles before the rising edge of RESETn. RESETn must be pulled high for normal operation. |
| 57 | VREF | I | RGMI I input voltage reference. Must be set to VDDOR/2 when used as 2.5V SSTL_2. Set to VDDOR when used as 2.5V/3.3V LVCMOS. |
| 4 | COMAn | I | COMA Control. Active low. If RESETn is low then COMAn has no effect. COMAn contains an internal 150 kohm pull-up resistor. 0 = In power saving mode 1 = Normal operation |

Table 7: Regulator & Reference

| 88E3016 | Pin Name | Type | Description |
|---------|-----------|------|--|
| 33 | RSET | I | Constant voltage reference. External 2 kohm 1% resistor connection to VSS is required for this pin. |
| 12 | DIS_REG12 | I | 1.2V Regulator Disable. Tie to VDDO to disable, Tie to VSS to enable. |
| 17 | CTRL25 | O | 2.5V Regulator Control. This signal ties to the base of the BJT. If the 2.5V regulator is not used it can be left floating. |

Table 8: Test

| 88E3016 | Pin Name | Type | Description |
|---------|----------|------|---|
| 36 | HSDACP | O | Test Pin. These pins have 49.9 ohm internal termination. They should be brought out to a via or pad to facilitate debug. If debug is not important and there are board space constraints, this pin can be left floating. |
| 35 | HSDACN | O | Test Pin. These pins have 49.9 ohm internal termination. They should be brought out to a via or pad to facilitate debug. If debug is not important and there are board space constraints, this pin can be left floating. |
| 32 | TSTPT | O | Test point. Leave unconnected. |



Table 9: Power & Ground

| 88E3016 | Pin Name | Type | Description |
|--|----------|--------|--|
| 28 | AVDD | Power | Analog supply. 2.5V ¹ . AVDD can be supplied externally with 2.5V, or via the 2.5V regulator. |
| 34 | AVDDC | Power | Analog supply - 2.5V or 3.3V ² . AVDDC must be supplied externally. Do not use the 2.5V regulator to power AVDDC. |
| 14 15 | AVDDR | Power | 1.2V Regulator supply - 2.5V AVDDR can be supplied externally with 2.5V, or via the 2.5V regulator. If the 1.2V regulator is not used, AVDDR must still be tied to 2.5V. |
| 16 | AVDDX | Power | 2.5V Regulator supply - 3.3V. AVDDX must be supplied externally. Note that this supply must be the same voltage as AVDDC. If the 2.5V regulator is not used, then it means a 2.5V supply is in the system. AVDDX (along with AVDDC) should be left floating. |
| 5 13 40 | DVDD | | Digital core supply - 1.2V. DVDD can be supplied externally with 1.2V, or via the 1.2V regulator. |
| 7 46 | VDDO | Power | 2.5V or 3.3V non-RGMII digital I/O supply ³ . VDDO must be supplied externally. Do not use the 2.5V regulator to power VDDO. |
| 52 56 | VDDOR | Power | 2.5V or 3.3V RGMII digital I/O supply ⁴ . VDDOR must be supplied externally. Do not use the 2.5V regulator to power VDDOR. |
| EPAD | VSS | Ground | Ground to digital core. The 64-pin QFN package has an exposed die pad (E-PAD) at its base. This E-PAD must be soldered to VSS. Refer to the package mechanical drawings for the exact location and dimensions of the EPAD. |
| 19 20 21 22 23 24 27 29 37 47 | NC | NC | No Connect. These pins are not bonded to the die and can be tied to anything. |

1. AVDD supplies the MDIP/N[1:0] pins.
2. AVDDC supplies the XTAL_IN and XTAL_OUT pins.
3. VDDO supplies the SIGDET, MDC, MDIO, RESETn, LED[2:0], CONFIG[3:0], TDI, TMS, TCK, TRSTn, TDO, COMAn, DIS_REG12, CTRL25, HSDAC, and TSTPT pins.
4. VDDOR supplies the TXD[3:0], TX_CLK, TX_CTRL, RXD[3:0], RX_CLK, and RX_CTRL pins.

Table 10: I/O State at Various Test or Reset Modes

| Pin(s) | Isolate | Loopback | Software Reset | Hardware Reset | Power Down | Power Down and Isolate |
|--|----------------|-----------------|--|-----------------------|--|-------------------------------|
| MDIP/ N[1:0] | Active | Active | Tri-state | Tri-state | Tri-state | Tri-state |
| TX_CLK | Tri-state | Active | Active | Tri-state | Active | Tri-state |
| RXD[0] RXD[2] RXD[3] RXD[1] RX_DV RX_ER CRS COL | Tri-state | Active | Low | Low | Low | Tri-state |
| RX_CLK | Tri-state | Active | Reg. 28.1 state 1 = Active 0 = Low | Low | Reg. 28.1 state 1 = Active 0 = Low | Tri-state |
| MDIO | Active | Active | Active | Tri-state | Active | Active |
| LED | Active | Active | Active | High | High | High |
| TDO | Tri-state | Tri-state | Tri-state | Tri-state | Tri-state | Tri-state |



1.2.2 88E3016 64-Pin QFN Assignments - Alphabetical by Signal Name

| Pin # | Pin Name | Pin # | Pin Name |
|-------|-------------------|-------|--------------------|
| 28 | AVDD | 29 | NC |
| 34 | AVDDC | 37 | NC |
| 14 | AVDDR | 47 | NC |
| 15 | AVDDR | 10 | RESET _n |
| 16 | AVDDX | 33 | RSET |
| 4 | COMA _n | 53 | RX_CLK |
| 64 | CONFIG[0] | 49 | RX_CTRL |
| 1 | CONFIG[1] | 50 | RXD[0] |
| 2 | CONFIG[2] | 51 | RXD[1] |
| 3 | CONFIG[3] | 54 | RXD[2] |
| 17 | CTRL25 | 55 | RXD[3] |
| 12 | DIS_REG12 | 18 | SIGDET |
| 5 | DVDD | 42 | TCK |
| 13 | DVDD | 43 | TDI |
| 40 | DVDD | 44 | TDO |
| 35 | HSDACN | 41 | TMS |
| 36 | HSDACP | 11 | TRST _n |
| 6 | LED[0] | 32 | TSTPT |
| 8 | LED[1] | 60 | TX_CLK |
| 9 | LED[2] | 63 | TX_CTRL |
| 48 | MDC | 58 | TXD[0] |
| 30 | MDIN[0] | 59 | TXD[1] |
| 25 | MDIN[1] | 61 | TXD[2] |
| 45 | MDIO | 62 | TXD[3] |
| 31 | MDIP[0] | 7 | VDDO |
| 26 | MDIP[1] | 46 | VDDO |
| 19 | NC | 52 | VDDOR |
| 20 | NC | 56 | VDDOR |
| 21 | NC | 57 | VREF |
| 22 | NC | EPAD | VSS |
| 23 | NC | 38 | XTAL_IN |
| 24 | NC | 39 | XTAL_OUT |
| 27 | NC | | |

Section 2. Functional Description

Figure 2 shows the functional block for the 88E3016 device. The transmitter and transmit PCS block are fully described on page 21. The receiver and receive PCS block are fully described on page 21.

Figure 2: 88E3016 Device Functional Block Diagram

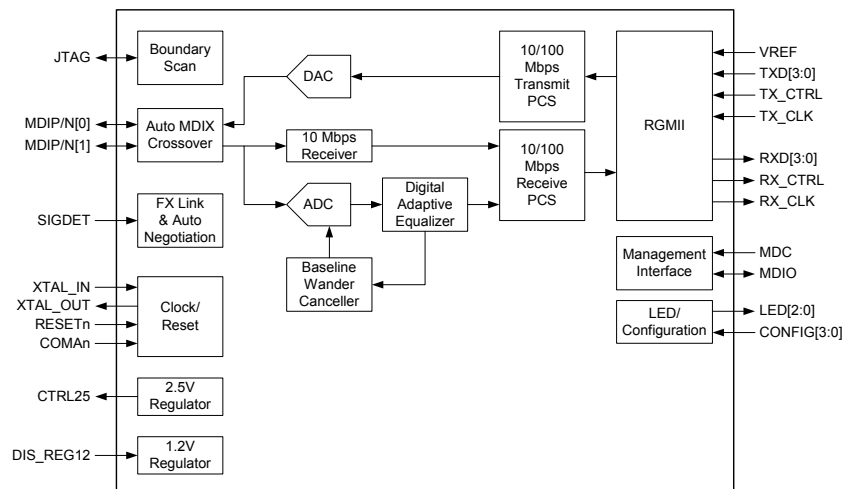

2.1 Reduced Gigabit Media Independent Interface (RGMII)

The 88E3016 device supports the RGMII specification (Version 1.2a, 9/22/2000, version 2.0, 04/2002 - except instead of HSTL, it supports 2.5V SSTL_2).

Figure 3: RGMII Signal Diagram

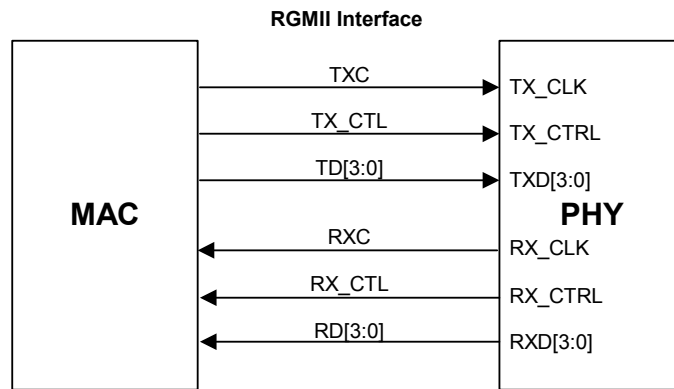

The interface runs at 2.5 MHz for 10 Mbps and 25 MHz for 100 Mbps. The TX_CLK signal is always generated by the MAC, and the RX_CLK signal is generated by the PHY.

During packet reception, RX_CLK may be stretched on either the positive or negative pulse to accommodate the transition from the free running clock to a data synchronous clock domain. When the speed of the PHY changes, a similar stretching of the positive or negative pulse is allowed. No glitching of the clocks is allowed during speed transitions.

The MAC must hold TX_CTRL low until the MAC has ensured that TX_CTRL is operating at the same speed as the PHY.

2.2 Serial Management Interface

The serial management interface provides access to the internal registers via the MDC and MDIO pins and is compliant to IEEE 802.3u section 22. MDC is the management data clock input and can run from DC to a maximum rate of 8.33 MHz. MDIO is the management data input/output and is a bi-directional signal that runs synchronously to MDC. The MDIO pin requires a 1.5 kohm pull-up resistor that pulls the MDIO high during idle and turnaround times.

2.2.1 MDC/MDIO Read and Write Operations

All the relevant serial management registers are implemented as well as several optional registers. A description of the registers can be found in [Section 3. "Register Description" on page 48](#).

Figure 4: Typical MDC/MDIO Read Operation

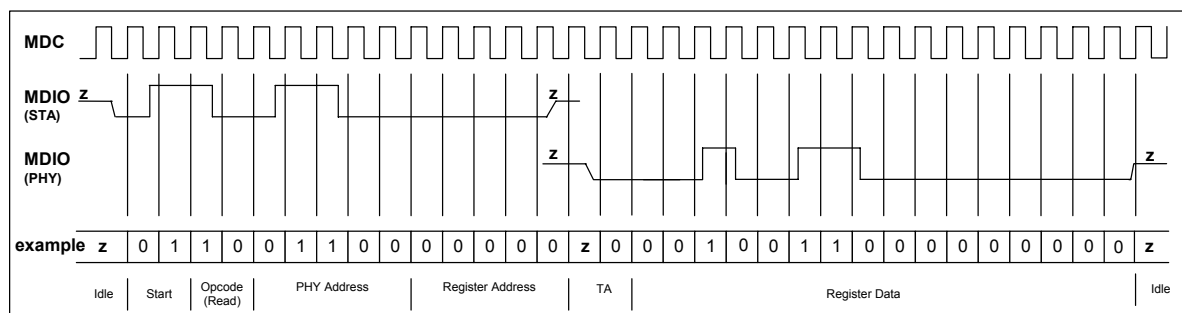

Figure 5: Typical MDC/MDIO Write Operation

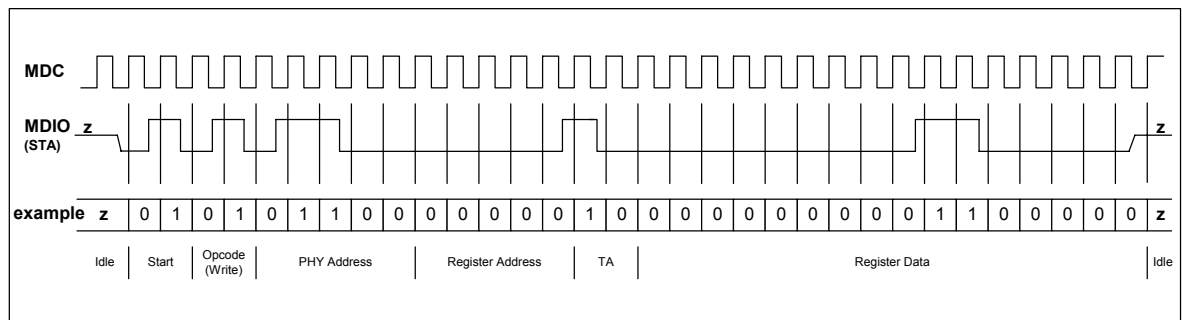

Table 11 is an example of a read operation.

Table 11: Serial Management Interface Protocol

| 32-Bit Preamble | Start of Frame | Opcode Read = 10 Write = 01 | 5-Bit Phy Device Address | 5-Bit Phy Register Address | 2-Bit Turn-around Read = z0 Write = 10 | 16-Bit Data Field | Idle |
|-----------------|----------------|-----------------------------------|--------------------------|----------------------------|--|-------------------|----------|
| 11111111 | 01 | 10 | 01100 | 00000 | z0 | 0001001100000000 | 11111111 |

2.2.2 Preamble Suppression

The 88E3016 devices are permanently programmed for preamble suppression. A minimum of one idle bit is required between operations.

2.2.3 Programming Interrupts

When Register 22:11:8 is set to 1110, the interrupt functionality is mapped to the LED[2] pin. The interrupt function drives the LED[2] pin active whenever an interrupt event is enabled by programming register 18. The polarity of the interrupt signal is determined by Register 25.14. This function minimizes the need for polling via the serial management interface. Table 12 shows the interrupts that may be programmed.

Table 12: Programmable Interrupts

| Register Address | Programmable Interrupts |
|------------------|---|
| 18.14 | Speed Changed Interrupt Enable |
| 18.13 | Duplex Changed Interrupt Enable |
| 18.12 | Page Received Interrupt Enable |
| 18.11 | Auto-Negotiation Completed Interrupt Enable |
| 18.10 | Link Status Changed Interrupt Enable |
| 18.9 | Symbol Error Interrupt Enable |
| 18.8 | False Carrier Interrupt Enable |
| 18.7 | FIFO Over/Underflow Interrupt Enable |
| 18.6 | MDI/MDIX Crossover Changed Enable |
| 18.4 | Energy Detect Changed Enable |
| 18.1 | Polarity Changed Enable |
| 18.0 | Jabber Interrupt Enable |

Register 18 determines whether the LED[2] pin is asserted when an interrupt event occurs. Register 19 reports interrupt status. When an interrupt event occurs, the corresponding bit in register 19 is set and remains set until register 19 is read via the serial management interface. When interrupt enable bits are not set in register 18, interrupt status bits in register 19 are still set when the corresponding interrupt events occur. However, the LED[2] pin is not asserted.

The LED[2] pin is active as long as at least one interrupt status bit is set in register 19 with its corresponding interrupt enable bit set in register 18, and Register 22:11:8 = 1110.

To de-assert the LED[2] pin:

- Clear of register 19 via a serial management read
- Disable the interrupt enable by writing register 18

2.3 Transmit and Receive Functions

The transmit and receive paths for the 88E3016 device are described in the following sections.

2.3.1 Transmit Side Network Interface

2.3.1.1 Multi-mode TX Digital to Analog Converter

The 88E3016 device incorporates a multi-mode transmit DAC to generate filtered MLT-3, NRZI, or Manchester coded symbols. The transmit DAC performs signal wave shaping to reduce EMI. The transmit DAC is designed for very low parasitic loading capacitances to improve the return loss requirement, which allows the use of low cost transformers.

2.3.1.2 Slew Rate Control and Waveshaping

In 100BASE-TX mode, slew rate control is used to minimize high frequency EMI. In 10BASE-T mode, the output waveform is pre-equalized via a digital filter.

2.3.2 Encoder

2.3.2.1 100BASE-TX

In 100BASE-TX mode, the transmit data stream is 4B/5B encoded, serialized, and scrambled. Upon initialization, the initial scrambling seed is determined by the PHY address. The datastream is then MLT-3 coded.

2.3.2.2 10BASE-T

In 10BASE-T mode, the transmit data is serialized and converted to Manchester encoding.

2.3.2.3 100BASE-FX

In 100BASE-FX mode, the transmit data stream is 4B/5B encoded, serialized, and converted to NRZI.

2.3.3 Receive Side Network Interface

2.3.3.1 Analog to Digital Converter

The 88E3016 device incorporates an advanced high speed ADC on each receive channel with greater resolution for better SNR, and therefore, lower error rates. Patented architectures and design techniques result in high differential and integral linearity, high power supply noise rejection, and low metastability error rate.

2.3.3.2 Baseline Wander Cancellor

The 88E3016 device employs an advanced baseline wander cancellation circuit to automatically compensate for this DC shift. It minimizes the effect of DC baseline shift on the overall error rate.

2.3.3.3 Digital Adaptive Equalizer

The digital adaptive equalizer removes inter-symbol interference at the receiver. The digital adaptive equalizer takes unequalized signals from ADC output and uses a combination of feedforward equalizer (FFE) and decision feedback equalizer (DFE) for the best-optimized signal-to-noise (SNR) ratio.

2.3.3.4 Link Monitor

The link monitor is responsible for determining if link is established with a link partner. In 10BASE-T mode, link monitor function is performed by detecting the presence of valid link pulses (NLPs) on the MDI± pins.

In 100BASE-TX mode, link is established by scrambled idles.

See Section 2.8 for unidirectional enable.

2.3.3.5 Copper Signal Detection

In 100BASE-TX mode, the signal detection function is based on the receive signal energy detected on the MDI± pins that is continuously qualified by the squelch detect circuit, and the local receiver acquiring lock.

2.3.3.6 Fiber Signal Detection

The SIGDET pin is used to qualify whether there is receive energy on the line. Register 16.6 determines the polarity of the SIGDET pin. When Register 16.6 is set low, the SIGDET pin polarity is active high, otherwise the polarity is active low.

2.3.4 Decoder

2.3.4.1 100BASE-TX

In 100BASE-TX mode, the receive data stream is recovered and converted to NRZ. The NRZ stream is descrambled and aligned to the symbol boundaries. The aligned data is then parallelized and 5B/4B decoded. The receiver does not attempt to decode the data stream unless the scrambler is locked. The descrambler “locks” to the *scrambler* state after detecting a sufficient number of consecutive idle code-groups. Once locked, the descrambler continuously monitors the data stream to make sure that it has not lost synchronization. The descrambler is always forced into the *unlocked* state when a link failure condition is detected, or when insufficient idle symbols are detected.

2.3.4.2 10BASE-T

In 10BASE-T mode, the recovered 10BASE-T signal is decoded from Manchester to NRZ, and then aligned. The alignment is necessary to insure that the start of frame delimiter (SFD) is aligned to the nibble boundary.

2.3.4.3 100BASE-FX

In 100BASE-FX mode the receive data stream is received and converted to NRZ. The decoding process is identical to 100BASE-TX except no descrambling is necessary.

2.3.5 Auto-Negotiation

The 88E3016 device can auto-negotiate to operate in 10BASE-T or 100BASE-TX

If Auto-Negotiation is enabled, then the 88E3016 devices negotiate with the link partner to determine the speed and duplex with which to operate. If the link partner is unable to Auto-Negotiate, the 88E3016 devices go into the parallel detect mode to determine the speed of the link partner. Under parallel detect mode, the duplex mode is fixed at half-duplex.

2.3.5.1 Register Update

Auto-Negotiation is initiated upon any of the following conditions:

- Power up reset
- Hardware reset
- Software reset
- Restart Auto-Negotiation
- Transition from power down to power up
- Changing from the *link-up* state to the *linkfail* state

Changes to the AnegEn, SpeedLSB, and Duplex bits (Registers 0.12, 0.13, and 0.8, respectively) do not take effect unless one of the following takes place:

- Software reset (SWReset bit - Register 0.15)
- Restart Auto-Negotiation (RestartAneg bit - Register 0.9)
- Transition from power down to power up (PwrDwn bit - Register 0.11)
- The link goes down

The Auto-Negotiation Advertisement register (Register 4) is internally latched once every time Auto-Negotiation enters the *ability detect* state in the arbitration state machine. Hence, a write into the Auto-Negotiation Advertisement Register has no effect once the 88E3016 devices begin to transmit Fast Link Pulses (FLPs). This guarantees that a sequence of FLPs transmitted is consistent with one another.

The Next Page Transmit register (Register 7) is internally latched once every time Auto-Negotiation enters the *next page exchange* state in the arbitration state machine.

2.3.5.2 Next Page Support

The 88E3016 devices support the use of next page during Auto-Negotiation. By default, the received base page and next page are stored in the Link Partner Ability register - Base Page (Register 5). The 88E3016 devices have an option to write the received next page into the Link Partner Next Page register - Register 8 - (similar to the description provided in the IEEE 802.3ab standard) by programming the Reg8NxtPg bit (PHY Specific Control Register - Register 16.12).

2.4 Power Management

The 88E3016 devices support advanced power management modes that conserve power.

Three low power modes are supported in the 88E3016 devices.

- IEEE 802.3 22.2.4.1.5 compliant power down
- Energy Detect+™
- COMA mode

IEEE 22.2.4.1.5 power down compliance allows for the PHY to be placed in a low-power consumption state by register control.

Energy Detect+™ allows the 88E3016 devices to wake up when energy is detected on the wire with the additional capability to wake up a link partner. The 10BASE-T link pulses are sent once every second while listening for energy on the line.

COMA mode shuts down the PHY into a low power state.

Table 13 displays the low power operating mode selection.

Table 13: Operating Mode Selection

| Power Mode | How to Activate Mode |
|-----------------|---|
| IEEE Power Down | PwrDwn bit write (Register 0.11) |
| Energy Detect+™ | Configuration option & register EDet bit write (Register 16.14) |
| COMA | COMAn pin |

2.4.1 IEEE Power Down Mode

The standard IEEE power down mode is entered by setting Register 0.11 equal to one. In this mode, the PHY does not respond to any MAC interface signals except the MDC/MDIO. It also does not respond to any activity on the CAT 5 cable.

In this power down mode, the PHY cannot wake up on its own by detecting activity on the CAT 5 cable. It can only wake up by clearing the PwrDwn bit to 0.

2.4.2 Energy Detect +™

When Register 16.14 is enabled, the Energy Detect +™ mode is enabled. In this mode, the PHY sends out a single 10 Mbps NLP (Normal Link Pulse) every one second. If the 88E3016 devices are in Energy Detect+ mode, it can wake a connected device. The 88E3016 devices also respond to MDC/MDIO.

2.4.3 Normal 10/100 Mbps Operation

Normal 10/100 Mbps operation can be entered by either using a configuration option or a register write during the energy detect mode.

2.4.4 COMA Mode

COMA mode shuts down the PHY into a low power state when it is not being used. When the PHY is in the COMA mode, the PHY is completely non-functional including register access. COMA mode is entered when the COMAn pin is set low.

If hardware reset pin (RESETn) and the COMA pin (COMAn) are asserted simultaneously the hardware reset function has priority over the COMA function.

If the PHY is disabled by removing any one or more of the external power supplies then the COMAn pin has no functionality. If the PHY is re-enabled then the proper power up sequence must be followed and a hardware reset applied before the PHY enters into the normal operating state.

If the reference clock (XTAL_IN, XTAL_OUT) stops when the PHY is disabled then the reference clock must be restarted and hardware reset must be applied before the PHY enters into the normal operating state.

If all external power supplies remain powered up and the reference clock continues to run then the PHY can enter and exit the COMA state without the need for hardware reset by simply controlling the COMAn pin. If XTAL_IN is attached to an oscillator instead of a crystal and if the reference clock can be cleanly switched between toggling at 25 MHz and non-toggling state without glitches then the XTAL_IN can be stopped if the relationship shown in [Figure 6](#) can be met. Tstop should be at least 1 ms. Tstart should be at least 0 ms.

Note that if the power supply and reference clock requirements can be met then all registers will retain their values during the COMA state.

Figure 6: XTAL_IN to COMAn Relationship

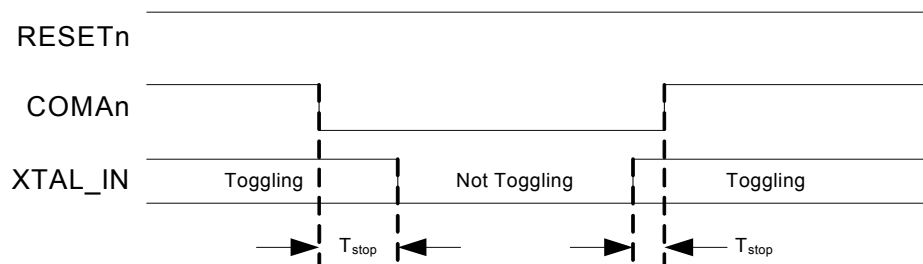

2.5 Regulators and Power Supplies

The 88E3016 device can operate from a single 2.5V or 3.3V supply if the regulators are used. If regulators are not used then a 2.5V and 1.2V supply are needed. Table 14 lists the valid combinations of regulator usage.

The VDDO supply can run at 2.5V or 3.3V and that the VDDOR supply can run at 2.5V or 3.3V. The 2.5V generated by the 2.5V regulator must not be used to supply VDDO or VDDOR.

The AVDDC and AVDDX must always be at the same voltage level, if AVDDX is not floating.

Table 14: Power Supply Options

| Supply Configuration Option | Pin Name | AVDDC | AVDDX | AVDD | AVDDR | DVDD |
|-----------------------------|---|---------------------|----------------|---------------|----------------|------------------------------|
| | Comment | High Voltage Analog | 2.5V Regulator | 2.5V Analog | 1.2V Regulator | 1.2V Digital |
| Single 3.3V supply | Need External BJT DIS_REG12 = VSS | 3.3V External | 3.3V External | 2.5V from BJT | 2.5V from BJT | 1.2V from Internal Regulator |
| 3.3V supply and 1.2V supply | Need External BJT DIS_REG12 = VDDO | 3.3V External | 3.3V External | 2.5V from BJT | 2.5V from BJT | 1.2V External |
| Single 2.5V supply | Do not connect external BJT DIS_REG12 = VSS | 2.5V External | Floating | 2.5V External | 2.5V External | 1.2V from Internal Regulator |
| 2.5V supply and 1.2V supply | Do not connect external BJT DIS_REG12 = VDDO | 2.5V External | Floating | 2.5V External | 2.5V External | 1.2V External |

The 2.5V regulator is not used if CTRL25 is left floating and not connected to a BJT.

The 1.2V regulator is disabled when DIS_REG12 is tied to VDDO. It is enabled when DIS_REG12 is tied to VSS.

2.5.1 AVDD

AVDD is used as the 2.5V analog supply. AVDD can be supplied externally with 2.5V, or via the 2.5V regulator.

2.5.2 AVDDC

AVDDC is used as the high voltage analog supply and can run on 2.5V or 3.3V.

AVDDC must be supplied externally. Do not use the 2.5V regulator to power AVDDC.

2.5.3 AVDDR

AVDDR is used as the 2.5V supply to the internal regulator that generates the 1.2V digital supply.

AVDDR can be supplied externally with 2.5V, or via the 2.5V regulator.

If the 1.2V regulator is not used, AVDDR must still be tied to 2.5V.

2.5.4 AVDDX

AVDDX is used as the 3.3V supply to the external regulator that generates the 2.5V supply.

If the 2.5V regulator is not used, then the CTRL25 pin should be left floating. In this particular case when the 2.5V regulator is not used, the AVDDX should be left floating.

AVDDX must be supplied externally. Note that this supply must be the same voltage as AVDDC.

2.5.5 DVDD

DVDD is used as the 1.2V digital supply.

DVDD can be supplied externally with 1.2V, or via the 1.2V regulator.

All DVDD pins should be shorted together. A decoupling capacitor should be attached to pin 13 of the 88E3016 device.

2.5.6 VDDO

VDDO supplies the non-RGMII digital I/O pins. The voltage range is 2.5V or 3.3V.

VDDO must be supplied externally. Do not use the 2.5V regulator to power VDDO.

2.5.7 VDDOR

VDDOR supplies the RGMII digital I/O pins. The voltage should be 2.5V or 3.3V.

VDDOR must be supplied externally. Do not use the 2.5V regulator to power VDDOR.

Three options are supported:

- 2.5V LVCMOS
- 3.3V LVCMOS
- 2.5V SSTL_2

The VREF pin should be set to $0.5 \times VDDOR$ for SSTL_2 behavior.

The VREF pin should be tied to VDDOR for LVCMOS behavior.

Note that 3.3V SSTL_2 is not supported.

2.6 Hardware Configuration

The 88E3016 device is configured by tying LED[1:0], VDDO, or VSS to CONFIG[3:0]. After the deassertion of RESET the 88E3016 will be hardware configured. The CONFIG pins should not be left floating.

The LED, CRS, and COL outputs a bit stream during initialization that is used by the CONFIG pin inputs. The bit values are latched at the deassertion of hardware reset. The bit stream mapping for 88E3016 is shown in [Table 15](#).

Table 15: 88E3016 Three bit Mapping

| Pin | Bits 2,1,0 |
|--------|------------|
| VSS | 000 |
| LED[0] | 001 |
| LED[1] | 010 |
| VDDO | 111 |

The 3 bits for each CONFIG pin are mapped as shown in [Table 16](#).

Table 16: Configuration Mapping

| Pin | Bit 2 | Bit 1 | Bit 0 |
|-----------|----------|----------|----------|
| CONFIG[0] | Reserved | PHYAD[1] | PHYAD[0] |
| CONFIG[1] | Reserved | PHYAD[3] | PHYAD[2] |
| CONFIG[2] | Reserved | ENA_XC | PHYAD[4] |
| CONFIG[3] | MODE[2] | MODE[1] | MODE[0] |

Each bit in the configuration is defined as shown in [Table 17](#).

Table 17: 88E3016 Configuration Definition

| Bits | Definition | Bits Affected |
|------------|--|---|
| PHYAD[4:0] | PHY Address | None |
| ENA_XC | 0 = Default Disable Auto-Crossover 1 = Default Enable Auto-Crossover | 16.5:4 In 100BASE-FX mode, this should be disabled. |
| MODE[2:0] | 000 = Copper - RGMII, Receive clock transition when data transitions 001 = Copper - RGMII, Receive clock transition when data stable 010 = Fiber - RGMII, Receive clock transition when data transitions 111 = Fiber - RGMII, Receive clock transition when data stable | 28.11:10, 28.3 |

Table 18 clarifies how the MODE[2:0] affects the register defaults.

Table 18: MODE[2:0] to Register Default Mapping

| MODE[2:0] | MAC Interface Mode | Fiber/Copper |
|------------------------|--------------------|--------------|
| | 28.11:10 | 28.3 |
| 000 (CONFIG3 = VSS) | 00 | 0 |
| 001 (CONFIG3 = LED[0]) | 01 | 0 |
| 010 (CONFIG3 = LED[1]) | 00 | 1 |
| 011 (CONFIG3 = LED[2]) | 10 | 0 |
| 111 (CONFIG3 = VDDO) | 01 | 1 |

2.7 Far End Fault Indication (FEFI)

Far end fault indication provides a mechanism for transferring information from the local station to the link partner that a remote fault has occurred in 100BASE-FX mode.

A remote fault is an error in the link that one station can detect while the other one cannot. An example of this is a disconnected wire at a station's transmitter. This station is receiving valid data and detects that the link is good via the link monitor, but is not able to detect that its transmission is not propagating to the other station.

A 100BASE-FX station that detects this remote fault modifies its transmitted idle stream pattern from all ones to a group of 84 ones followed by one zero. This is referred to as the FEFI idle pattern.

The FEFI function is controlled by the FEFI bits in 100BASE-FX mode.

Register 16.8 enables and disables the FEFI function. This bit has no effect in 10BASE-T and 100BASE-TX modes.

2.8 802.3ah Unidirectional Enable

The 88E3016 devices support the 802.3ah Unidirectional Enable function. When this function is enabled the PHY transmit path is enabled even if there is no link established. To enable unidirectional transmitting, all the following conditions must be met. Unidirectional is enabled (0.5 = 1). Auto-Negotiation is disabled (0.12 = 0). Full duplex enabled (0.8 = 1). Register 1.7 indicates that the PHY is able to transmit from the media independent interface regardless of whether the PHY has determined that a valid link has been established.

2.9 Virtual Cable Tester® Feature

The 88E3016 devices Virtual Cable Tester (VCT™) feature uses Time Domain Reflectometry (TDR) to determine the quality of the cables, connectors, and terminations. Some of the possible problems that can be diagnosed include opens, shorts, cable impedance mismatch, bad connectors, termination mismatch, and bad magnetics.

The 88E3016 devices transmit a signal of known amplitude (+1V) down each of the two pairs of an attached cable. It will conduct the cable diagnostic test on each pair, testing the TX and RX pairs sequentially. The transmitted signal will continue down the cable until it reflects off of a cable imperfection. The magnitude of the reflection and the time it takes for the reflection to come back are shown in the VCT registers 26.12:8, 26.7:0, 27.12:8, and 27.7:0 respectively.

Using the information from the VCT Registers 26 and 27, the distance to the problem location and the type of problem can be determined. For example, the time it takes for the reflection to come back, can be converted to distance using the cable fault distance trend line tables in [Figure 7](#). The polarity and magnitude of the reflection together with the distance will indicate the type of discontinuity. For example, a +1V reflection will indicate an open close to the PHY and a -1V reflection will indicate a short close to the PHY.

When the cable diagnostic feature is activated by setting Register 26.15 bit to one, a pre-determined amount of time elapses before a test pulse is transmitted. This is to ensure that the link partner loses link, so that it stops sending 100BASE-TX idles or 10 Mbit data packets. This is necessary to be able to perform the TDR test. The TDR test can be performed either when there is no link partner or when the link partner is Auto-Negotiating or sending 10 Mbit idle link pulses. If the 88E3016 devices receive a continuous signal for 125 ms, it will declare test failure because it cannot start the TDR test. In the test fail case, the received data is not valid. The results of the test are also summarized in Register 26.14:13 and 27.14:13.

- 11 = Test fail (The TDR test could not be run for reasons explained above)
- 00 = Valid test, normal cable (no short or open in cable)
- 10 = Valid test, open in cable (Impedance > 333 ohms)
- 01 = Valid test, short in cable (Impedance < 33 ohms)

The definition for shorts and opens is arbitrary and the user can define it anyway they desire using the information in the VCT registers. The impedance mismatch at the location of the discontinuity could also be calculated knowing the magnitude of the reflection. Refer to the App Note "Virtual Cable Tester® -- How to use TDR results" for details.

Figure 7: Cable Fault Distance Trend Line

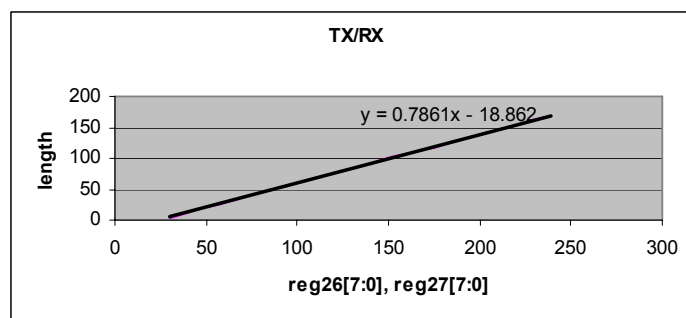

2.10 Auto MDI/MDIX Crossover

The 88E3016 devices automatically determine whether or not it needs to cross over between pairs so that an external crossover cable is not required. If the 88E3016 devices interoperate with a device that cannot automatically correct for crossover, the 88E3016 devices make the necessary adjustment prior to commencing Auto-Negotiation. If the 88E3016 devices interoperate with a device that implements MDI/MDIX crossover, a random algorithm as described in IEEE 802.3 section 40.4.4 determines which device performs the crossover.

When the 88E3016 devices interoperate with legacy 10BASE-T devices that do not implement Auto-Negotiation, the 88E3016 devices follow the same algorithm as described above since link pulses are present. However, when interoperating with legacy 100BASE-TX devices that do not implement Auto-Negotiation (i.e. link pulses are not present), the 88E3016 devices use signal detect to determine whether or not to crossover.

The Auto MDI/MDIX crossover function can be disabled via Register 16.5:4.

The 88E3016 devices are set to MDI mode by default if auto MDI/MDIX crossover is disabled at hardware reset.

The pin mapping in MDI and MDIX modes is specified in Table 19. Refer to [Figure 24 on page 98](#) for magnetics details.

Table 19: MDI/MDIX Pin Functions

| Physical Pin | MDIX | | MDI | |
|--------------|------------|----------|------------|----------|
| | 100BASE-TX | 10BASE-T | 100BASE-TX | 10BASE-T |
| MDIP/N[1] | Transmit | Transmit | Receive | Receive |
| MDIP/N[0] | Receive | Receive | Transmit | Transmit |

2.11 LED Interface

The LEDs can either be controlled by the PHY or controlled externally, independent of the state of the PHY.

2.11.1 Manual Override

External control is achieved by writing to the PHY Manual LED Override register 25.5:0. Any of the LEDs can be turned on, off, or made to blink at variable rates independent of the state of the PHY. This independence eliminates the need for driving LEDs from the MAC or the CPU. If the LEDs are driven from the CPU located at the back of the board, the LED lines crossing the entire board will pick up noise. This noise will cause EMI issues. Also, PCB layout will be more difficult due to the additional lines routed across the board.

When the LEDs are controlled by the PHY, the activity of the LEDs is determined by the state of the PHY. Each LED can be programmed to indicate various PHY states, with variable blink rate.

Any one of the LEDs can be controlled independently of the other LEDs (i.e one LED can be externally controlled while another LED can be controlled by the state of the PHY).

Table 20: Manual Override

| Bits | Field | Description |
|--------|-----------|---------------|
| 25.5:4 | ForceLED2 | 00 = Normal |
| | | 01 = Blink[1] |
| | | 10 = LED Off |
| | | 11 = LED On |
| 25.3:2 | ForceLED1 | 00 = Normal |
| | | 01 = Blink |
| | | 10 = LED Off |
| | | 11 = LED On |
| 25.1:0 | ForceLED0 | 00 = Normal |
| | | 01 = Blink |
| | | 10 = LED Off |
| | | 11 = LED On |

2.11.2 PHY Control

Manual override is disabled (25.5:4, 25.3:2, 25.1:0 is set to 00) then the LED behavior is defined by register 22.11:8, 22.7:4, and 22.3:0 (Table 21). If SPEED is selected then the LED behavior is further qualified by register 24.8:6, 24.5:3, and 24.2:0 (Table 22). See 2.2.3 "Programming Interrupts" when 22.11:8 is set to 1110.

Table 21: PHY LED Control

| Bits | Field | Description |
|------------------|-------|---|
| 22.11:8 | LED2 | LED2 Control. This is a global setting. |
| | | 0000 = COLX |
| | | 0001 = ERROR |
| | | 0010 = DUPLEX |
| | | 0011 = DUPLEX/COLX |
| | | 0100 = SPEED |
| | | 0101 = LINK |
| | | 0110 = TX |
| | | 0111 = RX |
| | | 1000 = ACT |
| | | 1001 = LINK/RX |
| | | 1010 = LINK/ACT |
| | | 1011 = ACT (Blink mode) |
| | | 1100 = TX (Blink Mode) |
| | | 1101 = RX (Blink Mode) |
| 1110 = Interrupt | | |
| 1111 = Force off | | |

Table 21: PHY LED Control (Continued)

| Bits | Field | Description |
|--------------------------|-------|---|
| 22.7:4 | LED1 | LED1 Control. This is a global setting. |
| | | 0000 = COLX |
| | | 0001 = ERROR |
| | | 0010 = DUPLEX |
| | | 0011 = DUPLEX/COLX |
| | | 0100 = SPEED |
| | | 0101 = LINK |
| | | 0110 = TX |
| | | 0111 = RX |
| | | 1000 = ACT |
| | | 1001 = LINK/RX |
| | | 1010 = LINK/ACT |
| | | 1011 = ACT (Blink mode) |
| | | 1100 = TX (Blink Mode) |
| | | 1101 = RX (Blink Mode) |
| 1110 = COLX (Blink Mode) | | |
| 1111 = Force off | | |

Table 21: PHY LED Control (Continued)

| Bits | Field | Description |
|------------------|-------|---|
| 22.3:0 | LED0 | LED0 Control. This is a global setting. |
| | | 0000 = COLX |
| | | 0001 = ERROR |
| | | 0010 = DUPLEX |
| | | 0011 = DUPLEX/COLX |
| | | 0100 = SPEED |
| | | 0101 = LINK |
| | | 0110 = TX |
| | | 0111 = RX |
| | | 1010 = LINK/ACT |
| | | 1011 = ACT (Blink mode) |
| | | 1100 = TX (Blink Mode) |
| | | 1101 = RX (Blink Mode) |
| | | 1110 = COLX (Blink Mode) |
| 1111 = Force off | | |

Table 22: Speed Dependent Behavior

| Bits | Field | Description |
|--------|------------|---|
| 24.8:6 | LED2 Speed | LED 2 Speed Select 000 = Active for 10BASE-T Link 001 = Reserved 010 = Reserved 011 = Reserved 100 = Reserved 101 = Active for 100BASE-X 110 = Off 111 = Reserved |
| 24.5:3 | LED1 Speed | LED 1 Speed Select 000 = Active for 10BASE-T Link 001 = Reserved 010 = Reserved 011 = Reserved 100 = Reserved 101 = Active for 100BASE-X 110 = Off 111 = Reserved |
| 24.2:0 | LED0 Speed | LED 0 Speed Select 000 = Active for 10BASE-T Link 001 = Reserved 010 = Reserved 011 = Reserved 100 = Reserved 101 = Active for 100BASE-X 110 = Off 111 = Reserved |

2.11.3 LED Polarity

The polarity of the LED in the active state can be set through register 25.14:12.

Table 23: LED Active Polarity

| Bits | Field | Description |
|-------|---------|---|
| 25.14 | InvLED2 | Invert LED2. This bit controls the active level of the LED2 pin. 0 = Active Low LED2 1 = Active High LED2 |
| 25.13 | InvLED1 | Invert LED1. This bit controls the active level of the LED1 pin. 0 = Active Low LED1 1 = Active High LED1 |
| 25.12 | InvLED0 | Invert LED0. This bit controls the active level of the LED0 pin. 0 = Active Low LED0 1 = Active High LED0 |

2.11.4 Stretching and Blinking

Some of the statuses can be pulse stretched. Pulse stretching is necessary because the duration of these status events might be too short to be observable on the LEDs. The pulse stretch duration can be programmed via Register 24.14:12. The default pulse stretch duration is set to 170 to 340 ms. The pulse stretch duration applies to all applicable LEDs.

Some of the statuses indicate multiple events by blinking LEDs. The blink period can be programmed via Register 24.11:9. The default blink period is set to 84 ms. The blink rate applies to all applicable LEDs.

2.12 Automatic and Manual Impedance Calibration

2.12.1 MAC Interface Calibration Circuit

The auto calibration is available for the MAC interface I/Os. The PHY runs the automatic calibration circuit with a 49 ohm impedance target by default after hardware reset. Other impedance targets are available by changing the impedance target and restarting the auto calibration through register writes. Individual NMOS and PMOS output transistors could be controlled for 38 to 80 ohm targets in various increments.

Manual NMOS and PMOS settings are available if the automatic calibration is not desired. If the PCB traces are different from 50 ohms, the output impedance of the MAC interface I/O buffers can be programmed to match the trace impedance. Users can adjust the NMOS and PMOS driver output strengths to perfectly match the transmission line impedance and eliminate reflections completely.

2.12.2 MAC Interface Calibration Register Definitions

If Register 29 = 0x000A, then Register 30 is defined as follows:

Table 24: Register 30 Page 10 - MAC Interface Calibration Definitions

| Reg bit | Function | Setting description | Mode | HW Reset | SW Reset |
|---------|----------------------|---|---------|-----------------------|----------|
| 15 | Restart Calibration | 0 = Normal 1 = Restart Bit 15 is a self-clearing register. Calibration will start once the register is cleared. | R/W | 0 | Retain |
| 14 | Calibration Complete | 1 = Calibration complete 0 = Calibration in progress | RO | 0 | Retain |
| 13 | Reserved | 0 | R/W | 0 | Retain |
| 12:8 | PMOS Value | 00000 = All fingers off ... 11111 = All fingers on The automatic calibrated values are stored here after calibration completes. Once the LATCH bit is set to 1, the new calibration value is written. The automatic calibrated value is lost. | R/W | Auto calibrated value | Retain |
| 7 | Reserved | 0 | R/W | 0 | Retain |
| 6 | Latch | 1 = Latch in new value. This bit self clears. (Used for manual settings) | R/W, SC | 0 | Retain |

Table 24: Register 30 Page 10 - MAC Interface Calibration Definitions (Continued)

| Reg bit | Function | Setting description | Mode | HW Reset | SW Reset |
|---------|------------------|---|------|-----------------------|----------|
| 5 | PMOS/NMOS select | 1 = PMOS value is written when LATCH is set to 1 0 = NMOS value is written when LATCH is set to 1 | R/W | 0 | Retain |
| 4:0 | NMOS Value | 00000 = All fingers off ... 11111 = All fingers on The automatic calibrated values are stored here after calibration completes. Once the LATCH bit is set to 1, the new calibration value is written. The automatic calibrated value is lost. | R/W | Auto calibrated value | Retain |

2.12.3 Changing Auto Calibration Targets

The PHY runs the automatic calibration circuit with a 49 ohm impedance target by default after hardware reset. Other impedance targets are available by changing the impedance target and restarting the auto calibration through register writes.

To change the auto calibration targets, write to the following registers:

Write to register 29 = 0x000B

Write to register 30, bit 6:4 = ppp (write new PMOS Target value)

Write to register 30, bit 2:0 = nnn (write new NMOS Target value)

Write to register 29 = 0x000A

Write to register 30 = 0x8000 (Restarts the auto calibration with the new target)

Example: To set the approximate 54 ohm auto calibration target, write the following:

Reg29 = 0x000B

Reg30, bit 6:4 = '011' and bit 2:0 = '011'

Reg29 = 0x000A

Reg30 = 0x8000

2.12.4 Manual Settings to The Calibration Registers

To use manual calibration, write to the following registers:

Write to register 29 = 0x000A

Write to register 30 = b'000P PPPP 011N NNNN -- adjusts PMOS strength

Write to register 30 = b'000P PPPP 0'10N NNNN -- adjusts NMOS strength

Where PPPPP is the 5 bit value for the PMOS strength.

Where NNNNN is the 5 bit value for the NMOS strength.

The value of PPPPP or NNNNN will depend on your board. The '11111' value enables all fingers for maximum drive strength, for minimum impedance. The '00000' value turns all fingers off for minimum drive strength, for maximum impedance. Use a scope to monitor the RX_CLK pin close to the destination. Start with the default auto-calibrated value and move in each direction to see how it affects signal integrity on your board.

Example: The automatic calibration has a 49 ohm target, but if the trace impedance on board was 60 ohms, you see reflections from a scope capture taken at the destination. See [Figure 10](#). After manual calibration, you see that the reflections are eliminated in [Figure 11](#).

[Figure 8](#) and [Figure 9](#) display the trend lines for 1.8V and 2.5V PMOS and NMOS impedance settings.

NOTE: The trend lines displayed in [Figure 8](#) and [Figure 9](#) use nominal values and may vary in production.

Figure 8: PMOS Output Impedance (1.8V, 2.5V) Trend Lines

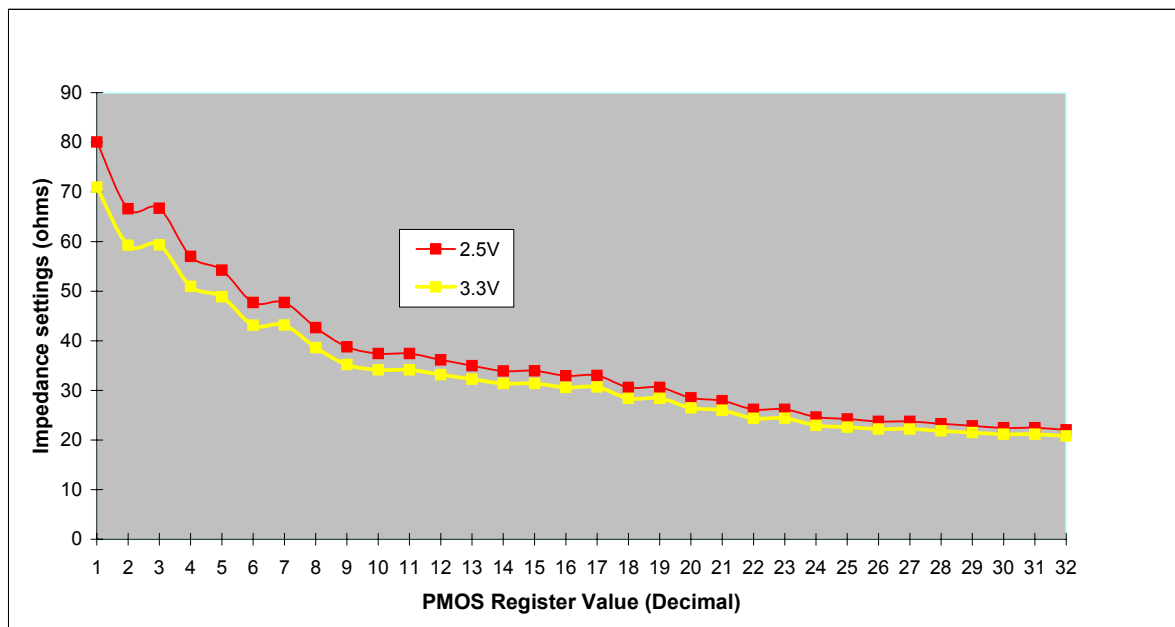
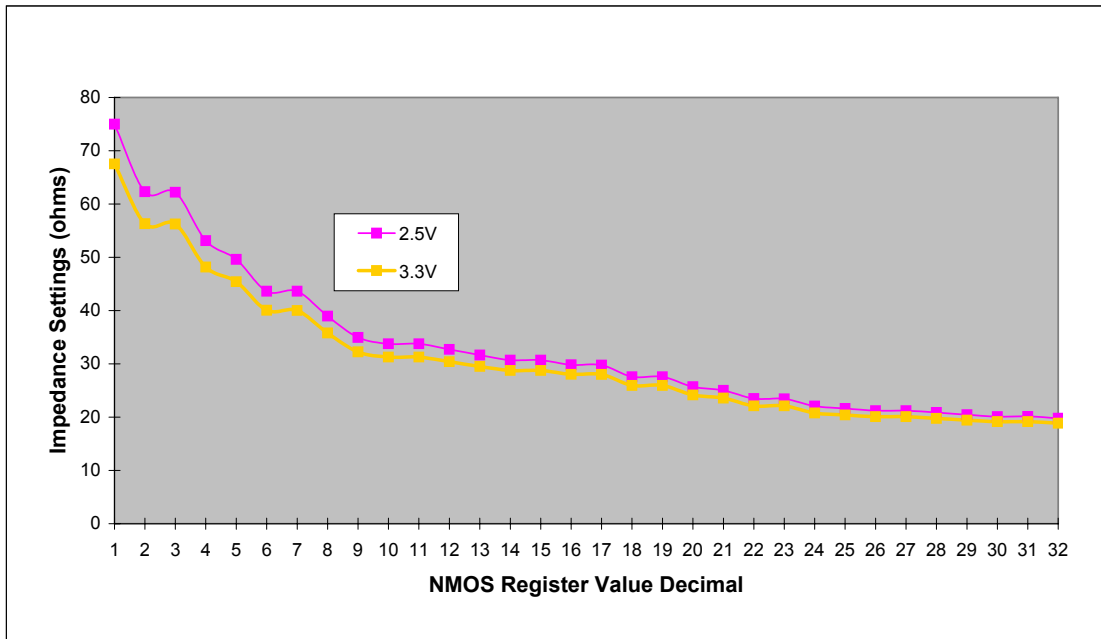

Figure 9: NMOS Output Impedance (1.8V, 2.5V) Trend Lines



Example: The automatic calibration has a 50 ohm target, but if the trace impedance on board was 60 ohms, you see reflections from a scope capture taken at the destination. Refer to [Figure 10](#). After manual calibration, you see that the reflections are eliminated as in [Figure 11](#).

Figure 10: Signal Reflections, using the 50 ohm Setting, 60 ohm line

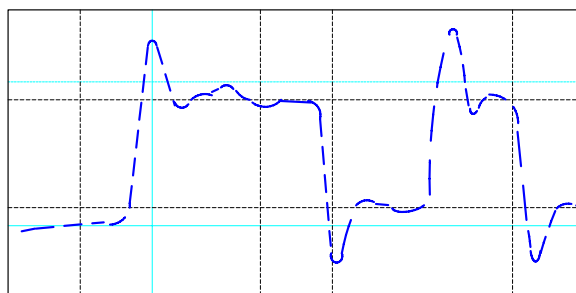
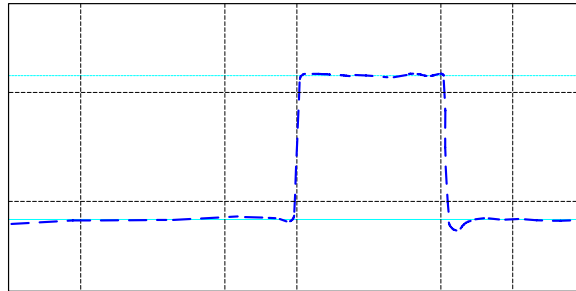

Figure 11: Clean signal after manual calibration for the 60 ohm





2.13 CRC Error Counter

The CRC counter, normally found in MACs, is available in the 88E3016 device. The error counter feature is enabled through register writes and the counter is stored in an eight bit register.

2.13.1 Enabling The CRC Error Counter

2.13.1.1 Enabling Counter

Write to the following registers will enable both counters.

Register 29: 0x0009 (points to page 9 of Register 30)

Register 30: 0x0001 (enables CRC error counter)

2.13.1.2 Disabling and Clearing Counter

Write to the following register will disable and clear both counters.

Register 29: 0x0009 (points to page 9 of Register 30)

Register 30: 0x0000 (disable and clear CRC error)

2.13.1.3 Reading Counter Content

To read the CRC counter, write to the following registers.

Register 29: 0x0009 (points to page 9 of Register 30)

Register 30: bits 15:8 (CRC error count is stored in these bits)

The counter does not clear on a read command. To clear the CRC error counter, disable and enable the counters. See Page 9 of Register 30 for details.

2.14 IEEE 1149.1 Controller

The IEEE 1149.1 standard defines a test access port and boundary-scan architecture for digital integrated circuits and for the digital portions of mixed analog/digital integrated circuits.

The standard provides a solution for testing assembled printed circuit boards and other products based on highly complex digital integrated circuits and high-density surface-mounting assembly techniques.

The 88E3016 device implements six basic instructions: bypass, sample/preload, extest, clamp, HIGH-Z, and ID CODE. Upon reset, ID_CODE instruction is selected. The instruction opcodes are shown in [Table 25](#).

Table 25: TAP Controller Op Codes

| Instruction | OpCode |
|----------------|----------|
| EXTEST | 00000000 |
| SAMPLE/PRELOAD | 00000001 |
| CLAMP | 00000010 |
| HIGH-Z | 00000011 |
| BYPASS | 11111111 |
| ID CODE | 00000100 |

The 88E3016 device reserves 5 pins called the Test Access Port (TAP) to provide test access Test Mode Select Input (TMS), Test Clock Input (TCK), Test Data Input (TDI), and Test Data Output (TDO), and Test Reset Input (TRSTn). To ensure race-free operation all input and output data is synchronous to the test clock (TCK). TAP input signals (TMS and TDI) are clocked into the test logic on the rising edge of TCK, while output signal (TDO) is clocked on the falling edge. For additional details refer to the IEEE 1149.1 Boundary Scan Architecture document.

2.14.1 Bypass Instruction

The bypass instruction uses the bypass register. The bypass register contains a single shift-register stage and is used to provide a minimum length serial path between the TDI and TDO pins of the 88E3016 device. This allows rapid movement of test data to and from other testable devices in the system.

The extest instruction allows circuitry external to the 88E3016 device (typically the board interconnections) to be tested. Prior to executing the extest instruction, the first test stimulus to be applied is shifted into the boundary-scan registers using the sample/preload instruction. Thus, when the change to the extest instruction takes place, known data is driven immediately from the 88E3016 device to its external connections.

2.14.2 Sample/Preload Instruction

The sample/preload instruction allows scanning of the boundary-scan register without causing interference to the normal operation of the 88E3016 device. Two functions are performed when this instruction is selected: sample and preload.

Sample allows a snapshot to be taken of the data flowing from the system pins to the on-chip test logic or vice versa, without interfering with normal operation. The snapshot is taken on the rising edge of TCK in the Capture-DR controller state, and the data can be viewed by shifting through the component's TDO output.

While sampling and shifting data out through TDO for observation, preload allows an initial data pattern to be shifted in through TDI and to be placed at the latched parallel output of the boundary-scan register cells that are connected to system output pins. This ensures that known data is driven through the system output pins upon

entering the extest instruction. Without preload, indeterminate data would be driven until the first scan sequence is complete. The shifting of data for the sample and preload phases can occur simultaneously. While data capture is being shifted out, the preload data can be shifted in.

One scan chain is available for the 88E3016 device.

Table 26: 88E3016 Boundary Scan Chain Order

| PIN | I/O |
|------------|---------------|
| MDIO | Output Enable |
| MDIO | Output |
| MDIO | Input |
| MDC | Input |
| (RGMII) | Output Enable |
| RX_CTRL | Output |
| RXD[0] | Output |
| RXD[1] | Output |
| RX_CLK | Output |
| RXD[2] | Output |
| RXD[3] | Output |
| TXD[0] | Input |
| TXD[1] | Input |
| TX_CLK | Input |
| TXD[2] | Input |
| TXD[3] | Input |
| TX_CTRL | Input |
| CONFIG[0] | Input |
| CONFIG[1] | Input |
| CONFIG[2] | Input |
| CONFIG[3] | Input |
| LED[0] | Output Enable |
| LED[0] | Output |
| LED[1] | Output Enable |
| LED[1] | Output |
| LED[2] | Output Enable |
| LED[2] | Output |
| COMAn | Input |
| RESET | Input |
| SIGDET | Input |

2.14.3 Extest Instruction

The extest instruction allows circuitry external to the PHY (typically the board interconnections) to be tested. Prior to executing the extest instruction, the first test stimulus to be applied is shifted into the boundary-scan registers

using the sample/preload instruction. Thus, when the change to the extest instruction takes place, known data is driven immediately from the PHY to its external connections.

2.14.4 The Clamp Instruction

The clamp instruction allows the state of the signals driven from component pins to be determined from the boundary-scan register while the bypass register is selected as the serial path between TDI and TDO. The signals driven from the component pins will not change while the clamp instruction is selected.

2.14.5 The HIGH-Z Instruction

The HIGH-Z instruction places the component in a state in which all of its system logic outputs are placed in an inactive drive state (e.g., high impedance). In this state, an in-circuit test system may drive signals onto the connections normally driven by a component output without incurring the risk of damage to the component.

2.14.6 ID CODE Instruction

The ID CODE contains the manufacturer identity, part and version.

Table 27: ID CODE

| Version | Part Number | Manufacturer Identity | |
|--------------|---------------------|-----------------------|---|
| Bit 31 to 28 | Bit 27 to 12 | Bit 11 to 1 | 0 |
| 0000 | 0000 0000 0010 0001 | 001 1110 1001 | 1 |



Section 3. Register Description

The IEEE defines only 32 registers address space for the PHY. In order to extend the number of registers address space available a paging mechanism is used. For register address 30, register 29 bits 4 to 0 are used to specify the page. There is no paging for registers 1 and 28.

In this document, the short hand used to specify the registers take the form register_page.bit:bit, register_page.bit, register.bit:bit, or register.bit.

For example:

Register 30 page 9 bits 15 to 8 are specified as 30_9.15:8.

Register 30 page 9 bit 0 is specified as 30_9.0.

Register 2 bit 3 to 0 is specified as 2.3:0.

Note that in this context the setting of the page register (register 29) has no effect.

Register 2 bit 3 is specified as 2.3.

Table 28 defines the register types used in the register map.

Table 28: Register Types

| Type | Description |
|---------------|--|
| LH | Register field with latching high function. If status is high, then the register is set to a one and remains set until a read operation is performed through the management interface or a reset occurs. |
| LL | Register field with latching low function. If status is low, then the register is cleared to zero and remains zero until a read operation is performed through the management interface or a reset occurs. |
| Retain | Value written to the register field does take effect without a software reset, and the register maintains its value after a software reset. |
| RES | Reserved for future use. All reserved bits are read as zero unless otherwise noted. |
| RO | Read only. |
| ROC | Read only clear. After read, register field is cleared to zero. |
| R/W | Read and write with initial value indicated. |
| RWC | Read/Write clear on read. All bits are readable and writable. After reset or after the register field is read, register field is cleared to zero. |
| SC | Self-Clear. Writing a one to this register causes the desired function to be immediately executed, then the register field is automatically cleared to zero when the function is complete. |
| Update | Value written to the register field does not take effect until soft reset is executed; however, the written value can be read even before the software reset. |
| WO | Write only. Reads to this type of register field return undefined data. |

Table 29: Register Map

| Register Name | Register Address | Table and Page |
|---|-------------------------|---------------------------------|
| PHY Control Register | Register 0 | Table 30, p. 51 |
| PHY Status Register | Register 1 | Table 31, p. 53 |
| PHY Identifier | Register 2 | Table 32, p. 55 |
| PHY Identifier | Register 3 | Table 33, p. 55 |
| Auto-Negotiation Advertisement Register | Register 4 | Table 34, p. 56 |
| Link Partner Ability Register (Base Page) | Register 5 | Table 35, p. 58 |
| Link Partner Ability Register (Next Page) | Register 5 | Table 36, p. 59 |
| Auto-Negotiation Expansion Register | Register 6 | Table 37, p. 60 |
| Next Page Transmit Register | Register 7 | Table 38, p. 61 |
| Link Partner Next Page Register | Register 8 | Table 39, p. 61 |
| PHY Specific Control Register | Register 16 | Table 40, p. 62 |
| PHY Specific Status Register | Register 17 | Table 41, p. 64 |
| PHY Interrupt Enable | Register 18 | Table 42, p. 65 |
| PHY Interrupt Status | Register 19 | Table 43, p. 66 |
| PHY Interrupt Port Summary | Register 20 | Table 44, p. 67 |
| Receive Error Counter | Register 21 | Table 45, p. 68 |
| LED Parallel Select Register | Register 22 | Table 46, p. 68 |
| PHY LED Control Register | Register 24 | Table 47, p. 69 |
| PHY Manual LED Override | Register 25 | Table 48, p. 71 |
| VCT™ Register for MDIP/N[0] Pins | Register 26 | Table 49, p. 72 |
| VCT™ Register for MDIP/N[1] Pins | Register 27 | Table 50, p. 73 |
| PHY Specific Control Register II | Register 28 | Table 51, p. 74 |
| Test Mode Select | Register 29 | Table 52, p. 75 |
| CRC Status Register | Register 30_9 | Table 53, p. 75 |
| RGMII Output Impedance Calibration Override | Register 30_10 | Table 54, p. 76 |
| RGMII Output Impedance Target | Register 30_11 | Table 55, p. 77 |

**Table 30: PHY Control Register
Register 0**

| Bits | Field | Mode | HW Rst | SW Rst | Description |
|------|----------|------------|--------|--------|---|
| 15 | SWReset | R/W, SC | 0x0 | 0x0 | PHY Software Reset Writing a 1 to this bit causes the PHY state machines to be reset. When the reset operation is done, this bit is cleared to 0 automatically. The reset occurs immediately. 0 = Normal operation 1 = PHY reset |
| 14 | Loopback | R/W | 0x0 | Retain | Enable Loopback Mode When loopback mode is activated, the transmitter data presented on TXD is looped back to RXD internally. The PHY has to be in forced 10 or 100 Mbps mode. Auto-Negotiation must be disabled. 0 = Disable loopback 1 = Enable loopback |
| 13 | SpeedLSB | R/W | 0x1 | Update | Speed Selection (LSB) When a speed change occurs, the PHY drops link and tries to determine speed when Auto-Negotiation is on. A write to this register bit has no effect unless any one of the following also occurs: Software reset is asserted (bit 15) or Power down (bit 11) transitions from power down to normal operation. 0 = 10 Mbps 1 = 100 Mbps |
| 12 | AnegEn | R/W | 0x1 | Update | Auto-Negotiation Enable A write to this register bit has no effect unless any one of the following also occurs: Software reset is asserted (bit 15, above), Power down (bit 11, below), or the PHY transitions from power down to normal operation. If the AnegEn bit is set to 0, the speed and duplex bits of the PHY Control Register (register 0) take effect. If the AnegEn bit is set to 1, speed and duplex advertisement is found in the Auto-Negotiation Advertisement Register (Register 4). 0 = Disable Auto-Negotiation Process 1 = Enable Auto-Negotiation Process |

Table 30: PHY Control Register (Continued)
Register 0

| Bits | Field | Mode | HW Rst | SW Rst | Description |
|------|--------------------------|------------|-------------|---------------|---|
| 11 | PwrDwn | R/W | 0x0 | Retain | Power Down Mode When the port is switched from power down to normal operation, software reset and restart Auto-Negotiation are performed even when bits Reset (bit 15, above) and Restart Auto-Negotiation (bit 9, below) are not set by the user. 0 = Normal operation 1 = Power down |
| 10 | Isolate | R/W | 0x0 | Retain | Isolate Mode 0 = Normal operation 1 = Isolate |
| 9 | RestartAneg | R/W, SC | 0x0 | Self Clear | Restart Auto-Negotiation Auto-Negotiation automatically restarts after hardware or software reset regardless of whether or not the restart bit is set. 0 = Normal operation 1 = Restart Auto-Negotiation Process |
| 8 | Duplex | R/W | 0x1 | Update | Duplex Mode Selection A write to this registers has no effect unless any one of the following also occurs: Software reset is asserted (bit 15), Power down (bit 11), or transitions from power down to normal operation. 0 = Half-duplex 1 = Full-duplex |
| 7 | ColTest | R/W | 0x0 | Retain | Collision Test Mode - This applies to E3010 only. 0 = Disable COL signal test 1 = Enable COL signal test |
| 6 | SpeedMSB | RO | Always 0 | Always 0 | Speed Selection Mode (MSB) Will always be 0. 0 = 100 Mbps or 10 Mbps |
| 5 | Unidirectional Enable | R/W | 0x0 | Retain | 0 = Enable transmit direction only when valid link is established. 1 = Enable transmit direction regardless of valid link if register 0.12 = 0 and 0.8 = 1. Otherwise enable transmit direction only when valid link is established. |
| 4:0 | Reserved | RO | Always 0 | Always 0 | Will always be 0. |

Table 31: PHY Status Register Register 1

| Bits | Field | Mode | HW Rst | SW Rst | Description |
|------|------------------------|--------|----------|----------|---|
| 15 | 100T4 | RO | Always 0 | Always 0 | 100BASE-T4 This protocol is not available. 0 = PHY not able to perform 100BASE-T4 |
| 14 | 100FDX | RO | Always 1 | Always 1 | 100BASE-T and 100BASE-X full-duplex 1 = PHY able to perform full-duplex |
| 13 | 100HDX | RO | Always 1 | Always 1 | 100BASE-T and 100BASE-X half-duplex 1 = PHY able to perform half-duplex |
| 12 | 10FDX | RO | Always 1 | Always 1 | 10BASE-T full-duplex 1 = PHY able to perform full-duplex |
| 11 | 10HPX | RO | Always 1 | Always 1 | 10BASE-T half-duplex 1 = PHY able to perform half-duplex |
| 10 | 100T2FDX | RO | Always 0 | Always 0 | 100BASE-T2 full-duplex. This protocol is not available. 0 = PHY not able to perform full-duplex |
| 9 | 100T2HDX | RO | Always 0 | Always 0 | 100BASE-T2 half-duplex This protocol is not available. 0 = PHY not able to perform half-duplex |
| 8 | ExtdStatus | RO | Always 0 | Always 0 | Extended Status 0 = No extended status information in Register 15 |
| 7 | Unidirectional Ability | RO | Always 1 | Always 1 | 1 = PHY able to transmit from media independent interface regardless of whether the PHY has determined that a valid link has been established |
| 6 | MFPPreSup | RO | Always 1 | Always 1 | MF Preamble Suppression Mode Must be always 1. 1 = PHY accepts management frames with preamble suppressed |
| 5 | AnegDone | RO | 0x0 | 0x0 | Auto-Negotiation Complete 0 = Auto-Negotiation process not completed 1 = Auto-Negotiation process completed |
| 4 | RemoteFault | RO, LH | 0x0 | 0x0 | Remote Fault Mode 0 = Remote fault condition not detected 1 = Remote fault condition detected |
| 3 | AnegAble | RO | Always 1 | Always 1 | Auto-Negotiation Ability Mode 1 = PHY able to perform Auto-Negotiation |

Table 31: PHY Status Register (Continued)
Register 1

| Bits | Field | Mode | HW Rst | SW Rst | Description |
|------|-----------|--------|-------------|-------------|---|
| 2 | Link | RO, LL | 0x0 | 0x0 | Link Status Mode This register indicates when link was lost since the last read. For the current link status, either read this register back-to-back or read RTLink (17.10). 0 = Link is down 1 = Link is up |
| 1 | JabberDet | RO, LH | 0x0 | 0x0 | Jabber Detect 0 = Jabber condition not detected 1 = Jabber condition detected |
| 0 | ExtdReg | RO | Always 1 | Always 1 | Extended capability mode. 1 = Extended register capabilities |

Table 32: PHY Identifier Register 2

| Bits | Field | Mode | HW Rst | SW Rst | Description |
|------|---|------|--------|--------|---|
| 15:0 | Organizationally Unique Identifier Bit 3:18 | RO | 0x0141 | 0x0141 | Marvell® OUI is 0x005043 0000 0000 0101 0000 0100 0011 ^ ^ bit 1.....bit 24 Register 2.[15:0] show bits 3 to 18 of the OUI. 101000001 ^ ^ bit 3.....bit 18 |

Table 33: PHY Identifier Register 3

| Bits | Field | Mode | HW Rst | SW Rst | Description |
|-------|----------|------|---------------|---------------|---|
| 15:10 | OUI LSB | RO | Always 000011 | Always 000011 | Organizationally Unique Identifier bits 19:24 00 0011 ^.....^ bit 19...bit 24 |
| 9:4 | ModelNum | RO | Always 100010 | Always 100010 | Model Number = 100010 |
| 3:0 | RevNum | RO | Varies | Varies | Revision Number Contact Marvell® FAEs for information on the device revision number. |

**Table 34: Auto-Negotiation Advertisement Register
Register 4**

| Bits | Field | Mode | HW Rst | SW Rst | Description |
|------|-------------------------|------|----------|----------|---|
| 15 | AnegAd NxtPage | R/W | 0x0 | Retain | Next Page 0 = Not advertised 1 = Advertise Values programmed into the Auto-Negotiation Advertisement Register have no effect unless Auto-Negotiation is restarted (RestartAneg 0.9) or link goes down. |
| 14 | Ack | RO | Always 0 | Always 0 | Must be 0. |
| 13 | AnegAd ReFault | R/W | 0x0 | Retain | Remote Fault Mode 0 = Do not set Remote Fault bit 1 = Set Remote Fault bit Values programmed into the Auto-Negotiation Advertisement Register have no effect unless Auto-Negotiation is restarted (RestartAneg 0.9) or link goes down. |
| 12 | Reserved | R/W | 0x0 | Retain | Must be 0. Reserved bits are R/W to allow for forward compatibility with future IEEE standards. Values programmed into the Auto-Negotiation Advertisement Register have no effect unless Auto-Negotiation is restarted (RestartAneg 0.9) or link goes down. |
| 11 | AnegAd Asymmetric Pause | R/W | 0x0 | Retain | Asymmetric Pause Mode 0 = Asymmetric PAUSE not implemented 1 = Asymmetric PAUSE implemented Values programmed into the Auto-Negotiation Advertisement Register have no effect unless Auto-Negotiation is restarted (RestartAneg 0.9) or link goes down. |
| 10 | AnegAd Pause | R/W | 0x0 | Retain | Pause Mode 0 = MAC PAUSE not implemented 1 = MAC PAUSE implemented Values programmed into the Auto-Negotiation Advertisement Register have no effect unless Auto-Negotiation is restarted (RestartAneg 0.9) or link goes down. |
| 9 | AnegAd 100T4 | R/W | 0x0 | Retain | 100BASE-T4 mode 0 = Not capable of 100BASE-T4 Must be 0. |
| 8 | AnegAd 100FDX | R/W | 0x1 | Retain | 100BASE-TX full-duplex Mode 0 = Not advertised 1 = Advertise Values programmed into the Auto-Negotiation Advertisement Register have no effect unless Auto-Negotiation is restarted (RestartAneg 0.9) or link goes down. |

**Table 34: Auto-Negotiation Advertisement Register (Continued)
Register 4**

| Bits | Field | Mode | HW Rst | SW Rst | Description |
|------|-----------------|------|-------------|-------------|---|
| 7 | AnegAd 100HDX | R/W | 0x1 | Retain | 100BASE-TX half-duplex Mode 0 = Not advertised 1 = Advertise Values programmed into the Auto-Negotiation Advertisement Register have no effect unless Auto-Negotiation is restarted (RestartAneg 0.9) or link goes down. |
| 6 | AnegAd 10FDX | R/W | 0x1 | Retain | 10BASE-TX full-duplex Mode 0 = Not advertised 1 = Advertise Values programmed into the Auto-Negotiation Advertisement Register have no effect unless Auto-Negotiation is restarted (RestartAneg 0.9) or link goes down. |
| 5 | AnegAd 10HDX | R/W | 0x1 | Retain | 10BASE-TX half-duplex Mode 0 = Not advertised 1 = Advertise Values programmed into the Auto-Negotiation Advertisement Register have no effect unless Auto-Negotiation is restarted (RestartAneg 0.9) or link goes down. |
| 4:0 | AnegAd Selector | R/W | Always 0x01 | Always 0x01 | Selector Field Mode 00001 = 802.3 |

Table 35: Link Partner Ability Register (Base Page) Register 5

| Bits | Field | Mode | HW Rst | SW Rst | Description |
|------|----------------|------|--------|--------|---|
| 15 | LPNxt Page | RO | 0x0 | 0x0 | Next Page Mode Base page will be overwritten if next page is received and if Reg8NxtPg (16.12) is disabled. When Reg8NxtPg (16.12) is enabled, then next page is stored in the Link Partner Next Page register, and the Link Partner Ability Register holds the base page. Received Code Word Bit 15 0 = Link partner not capable of next page 1 = Link partner capable of next page |
| 14 | LPAck | RO | 0x0 | 0x0 | Acknowledge Received Code Word Bit 14 0 = Link partner did not receive code word 1 = Link partner received link code word |
| 13 | LPRemote Fault | RO | 0x0 | 0x0 | Remote Fault Received Code Word Bit 13 0 = Link partner has not detected remote fault 1 = Link partner detected remote fault |
| 12:5 | LPTechAble | RO | 0x00 | 0x00 | Technology Ability Field Received Code Word Bit 12:5 |
| 4:0 | LPSelector | RO | 0x00 | 0x00 | Selector Field Received Code Word Bit 4:0 |

**Table 36: Link Partner Ability Register (Next Page)
Register 5**

| Bits | Field | Mode | HW Rst | SW Rst | Description |
|------|-----------|------|--------|--------|---|
| 15 | LPNxtPage | RO | -- | -- | Next Page Mode Base page will be overwritten if next page is received and if Reg8NxtPg (16.12) is disabled. When Reg8NxtPg (16.12) is enabled, then next page is stored in the Link Partner Next Page register, and Link Partner Ability Register holds the base page. Received Code Word Bit 15 |
| 14 | LPAck | RO | -- | -- | Acknowledge Received Code Word Bit 14 |
| 13 | LPMessAge | RO | -- | -- | Message Page Received Code Word Bit 13 |
| 12 | LPack2 | RO | -- | -- | Acknowledge 2 Received Code Word Bit 12 |
| 11 | LPToggle | RO | -- | -- | Toggle Received Code Word Bit 11 |
| 10:0 | LPData | RO | -- | -- | Message/Unformatted Field Received Code Word Bit 10:0 |

Table 37: Auto-Negotiation Expansion Register Register 6

| Bits | Field | Mode | HW Rst | SW Rst | Description |
|------|-----------------|-------|--------------|--------------|--|
| 15:5 | Reserved | RO | Always 0x000 | Always 0x000 | Reserved. The Auto-Negotiation Expansion Register is not valid until the AnegDone (1.5) indicates completed. |
| 4 | ParFaultDet | RO/LH | 0x0 | 0x0 | Parallel Detection Level 0 = A fault has not been detected via the Parallel Detection function 1 = A fault has been detected via the Parallel Detection function |
| 3 | LPNxtPg Able | RO | 0x0 | 0x0 | Link Partner Next Page Able 0 = Link Partner is not Next Page able 1 = Link Partner is Next Page able |
| 2 | LocalNxtPg Able | RO | Always 0x1 | Always 0x1 | Local Next Page Able This bit is equivalent to AnegAble. 1 = Local Device is Next Page able |
| 1 | RxNewPage | RO/LH | 0x0 | 0x0 | Page Received 0 = A New Page has not been received 1 = A New Page has been received |
| 0 | LPAnegAble | RO | 0x0 | 0x0 | Link Partner Auto-Negotiation Able 0 = Link Partner is not Auto-Negotiation able 1 = Link Partner is Auto-Negotiation able |

**Table 38: Next Page Transmit Register
Register 7**

| Bits | Field | Mode | HW Rst | SW Rst | Description |
|------|-----------|------|--------|--------|---|
| 15 | TxNxtPage | R/W | 0x0 | 0x0 | A write to the Next Page Transmit Register implicitly sets a variable in the Auto-Negotiation state machine indicating that the next page has been loaded. Transmit Code Word Bit 15 |
| 14 | Reserved | RO | 0x0 | 0x0 | Reserved Transmit Code Word Bit 14 |
| 13 | TxMessage | R/W | 0x1 | 0x1 | Message Page Mode Transmit Code Word Bit 13 |
| 12 | TxAck2 | R/W | 0x0 | 0x0 | Acknowledge2 Transmit Code Word Bit 12 |
| 11 | TxToggle | RO | 0x0 | 0x0 | Toggle Transmit Code Word Bit 11 |
| 10:0 | TxData | R/W | 0x001 | 0x001 | Message/Unformatted Field Transmit Code Word Bit 10:0 |

**Table 39: Link Partner Next Page Register
Register 8**

| Bits | Field | Mode | HW Rst | SW Rst | Description |
|------|-----------|------|--------|--------|--|
| 15 | RxNxtPage | RO | 0x0 | 0x0 | If Reg8NxtPg (16.12) is enabled, then next page is stored in the Link Partner Next Page register; otherwise, the Link Partner Next Page register is cleared to all 0's. Received Code Word Bit 15 |
| 14 | RxAck | RO | 0x0 | 0x0 | Acknowledge Received Code Word Bit 14 0 = Link partner not capable of next page 1 = Link partner capable of next page |
| 13 | RxMessage | RO | 0x0 | 0x0 | Message Page Received Code Word Bit 13 |
| 12 | RxAck2 | RO | 0x0 | 0x0 | Acknowledge 2 Received Code Word Bit 12 |
| 11 | RxToggle | RO | 0x0 | 0x0 | Toggle Received Code Word Bit 11 |
| 10:0 | RxData | RO | 0x000 | 0x000 | Message/Unformatted Field Received Code Word Bit 10:0 |

**Table 40: PHY Specific Control Register
Register 16**

| Bits | Field | Mode | HW Rst | SW Rst | Description |
|------|--------------|------|--------|--------|--|
| 15 | Reserved | R/W | 0x0 | Retain | |
| 14 | EDet | R/W | 0x0 | Retain | Energy Detect 0 = Disable 1 = Enable with sense and pulse Enable with sense only is not supported |
| 13 | DisNLP Check | R/W | 0x0 | 0x0 | Disable Normal Linkpulse Check Linkpulse check and generation disable have no effect, if Auto-Negotiation is enabled locally. 0 = Enable linkpulse check 1 = Disable linkpulse check |
| 12 | Reg8NxtPg | R/W | 0x0 | 0x0 | Enable the Link Partner Next Page register to store Next Page. If set to store next page in the Link Partner Next Page register (register 8), then 802.3u is violated to emulate 802.3ab. 0 = Store next page in the Link Partner Ability Register (Base Page) register (register 5). 1 = Store next page in the Link Partner Next Page register. |
| 11 | DisNLPGen | R/W | 0x0 | 0x0 | Disable Linkpulse Generation. Linkpulse check and generation disable have no effect, when Auto-Negotiation is enabled locally. 0 = Enable linkpulse generation 1 = Disable linkpulse generation |
| 10 | Reserved | R/W | 0x0 | 0x0 | Set to 0 |
| 9 | DisScrambler | R/W | 0x0 | Retain | Disable Scrambler If either 100BASE-FX or 10BASE-T forced mode is selected, then the scrambler is disabled at hardware reset. However, when 100BASE-TX is selected, this register bit equals 0. 0 = Enable scrambler 1 = Disable scrambler |
| 8 | DisFEFI | R/W | 0x1 | Retain | Disable FEFI FEFI is automatically disabled regardless of the state of this bit if copper mode is selected. 0 = Enable FEFI 1 = Disable FEFI |

**Table 40: PHY Specific Control Register (Continued)
Register 16**

| Bits | Field | Mode | HW Rst | SW Rst | Description | | | | | | |
|--------|-----------------|------|-----------|--------|---|--------|--------|---|----|---|----|
| 7 | ExtdDistance | R/W | 0x0 | 0x0 | Enable Extended Distance When using cable exceeding 100 meters, the 10BASE-T receive threshold must be lowered in order to detect incoming signals. 0 = Normal 10BASE-T receive threshold 1 = Lower 10BASE-T receive threshold | | | | | | |
| 6 | SIGDET Polarity | R/W | 0x0 | Update | 0 = SIGDET Active High 1 = SIGDET Active Low | | | | | | |
| 5:4 | AutoMDI[X] | R/W | See Desc. | Update | MDI/MDIX Crossover During Hardware Reset register 16.5:4 defaults as follows <table style="margin-left: 20px;"> <tr> <td>ENA_XC</td> <td>16.5:4</td> </tr> <tr> <td>0</td> <td>00</td> </tr> <tr> <td>1</td> <td>11</td> </tr> </table> This setting can be changed by writing to these bits followed by software reset. 00 = Transmit on pins MDIP/N[0], Receive on pins MDIP/N[1] 01 = Transmit on pins MDIP/N[1], Receive on pins MDIP/N[0] 1x = Enable Automatic Crossover | ENA_XC | 16.5:4 | 0 | 00 | 1 | 11 |
| ENA_XC | 16.5:4 | | | | | | | | | | |
| 0 | 00 | | | | | | | | | | |
| 1 | 11 | | | | | | | | | | |
| 3:2 | Reserved | R/W | 0x0 | Retain | | | | | | | |
| 1 | AutoPol | R/W | 0x0 | 0x0 | Polarity Reversal If Automatic polarity is disabled, then the polarity is forced to be normal in 10BASE-T mode. Polarity reversal has no effect in 100BASE-TX mode. This bit only controls polarity correction at the inputs. The output polarity is not programmable. 0 = Enable automatic polarity reversal 1 = Disable automatic polarity reversal | | | | | | |
| 0 | DisJabber | R/W | 0x0 | 0x0 | Disable Jabber Jabber has no effect in full-duplex or in 100BASE-X mode. 0 = Enable jabber function 1 = Disable jabber function | | | | | | |

**Table 41: PHY Specific Status Register
 Register 17**

| Bits | Field | Mode | HW Rst | SW Rst | Description |
|------|-----------|--------|------------|------------|--|
| 15 | Reserved | RO | 0x0 | 0x0 | 0 |
| 14 | ResSpeed | RO | 0x1 | Retain | Resolved Speed The values are updated after the completion of Auto-Negotiation. The registers retain their values during software reset. This bit is valid only after the resolved bit 11 is set. 0 = 10 Mbps 1 = 100 Mbps. |
| 13 | ResDuplex | RO | 0x1 | Retain | Resolved Duplex Mode The values are updated after the completion of Auto-Negotiation. The registers retain their values during software reset. This bit is valid only after the resolved bit 11 is set. 0 = Half-duplex 1 = Full-duplex |
| 12 | RcvPage | RO, LH | 0x0 | 0x0 | Page Receive Mode 0 = Page not received 1 = Page received |
| 11 | Resolved | RO | 0x0 | 0x0 | Speed and Duplex Resolved. Speed and duplex bits (14 and 13) are valid only after the Resolved bit is set. The Resolved bit is set when Auto-Negotiation has resolved the highest common capabilities or Auto-Negotiation is disabled. 0 = Not resolved 1 = Resolved |
| 10 | RTLink | RO | 0x0 | 0x0 | Link (real time) 0 = Link down 1 = Link up |
| 9:7 | Reserved | RES | Always 000 | Always 000 | Always 000. |
| 6 | MDI/MDIX | RO | 0x0 | 0x0 | MDI/MDIX Crossover Status 0 = Transmit on pins TXP/TXN, Receive on pins RXP/RXN 1 = Transmit on pins RXP/RXN, Receive on pins TXP/TXN |
| 5 | Reserved | RES | Always 0 | Always 0 | Always 0. |
| 4 | Sleep | RO | 0x0 | 0x0 | Energy Detect Status 0 = Chip is not in sleep mode (Active) 1 = Chip is in sleep mode (No wire activity) |

**Table 41: PHY Specific Status Register (Continued)
Register 17**

| Bits | Field | Mode | HW Rst | SW Rst | Description |
|------|------------|------|-----------|-----------|--|
| 3:2 | Reserved | RES | Always 00 | Always 00 | Always 00. |
| 1 | RTPolarity | RO | 0x0 | 0x0 | Polarity (real time) 0 = Normal 1 = Reversed |
| 0 | RTJabber | RO | 0x0 | Retain | Jabber (real time) 0 = No Jabber 1 = Jabber |

**Table 42: PHY Interrupt Enable
Register 18**

| Bits | Field | Mode | HW Rst | SW Rst | Description |
|------|----------------|------|--------|--------|--|
| 15 | Reserved | R/W | 0x0 | Retain | 0 |
| 14 | SpeedIntEn | R/W | 0x0 | Retain | Speed Changed Interrupt Enable 0 = Interrupt disable 1 = Interrupt enable |
| 13 | DuplexIntEn | R/W | 0x0 | Retain | Duplex Changed Interrupt Enable 0 = Interrupt disable 1 = Interrupt enable |
| 12 | RxPageIntEn | R/W | 0x0 | Retain | Page Received Interrupt Enable 0 = Interrupt disable 1 = Interrupt enable |
| 11 | AnegDone IntEn | R/W | 0x0 | Retain | Auto-Negotiation Completed Interrupt Enable 0 = Interrupt disable 1 = Interrupt enable |
| 10 | LinkIntEn | R/W | 0x0 | Retain | Link Status Changed Interrupt Enable 0 = Interrupt disable 1 = Interrupt enable |
| 9 | SymErrIntEn | R/W | 0x0 | Retain | Symbol Error Interrupt Enable 0 = Interrupt disable 1 = Interrupt enable |
| 8 | FlsCrsIntEn | R/W | 0x0 | Retain | False Carrier Interrupt Enable 0 = Interrupt disable 1 = Interrupt enable |
| 7 | FIFOErrInt | R/W | 0x0 | Retain | FIFO Over/Underflow Interrupt Enable 0 = Interrupt disable 1 = Interrupt enable |

**Table 42: PHY Interrupt Enable (Continued)
Register 18**

| Bits | Field | Mode | HW Rst | SW Rst | Description |
|------|---------------|------|--------|--------|--|
| 6 | MDI[x]IntEn | R/W | 0x0 | 0x0 | MDI/MDIX Crossover Changed Interrupt Enable 0 = Interrupt disable 1 = Interrupt enable |
| 5 | Reserved | RES | 0x0 | Retain | Must be 0. |
| 4 | EDetIntEn | R/W | 0x0 | Retain | Energy Detect Interrupt Enable 0 = Disable 1 = Enable |
| 3:2 | Reserved | RES | 0x0 | Retain | Must be 00. |
| 1 | PolarityIntEn | R/W | 0x0 | Retain | Polarity Changed Interrupt Enable 0 = Interrupt disable 1 = Interrupt enable |
| 0 | JabberIntEn | R/W | 0x0 | Retain | Jabber Interrupt Enable 0 = Interrupt disable 1 = Interrupt enable |

**Table 43: PHY Interrupt Status
Register 19**

| Bits | Field | Mode | HW Rst | SW Rst | Description |
|------|-------------|--------|--------|--------|--|
| 15 | Reserved | RO | 0x0 | 0x0 | 0 |
| 14 | SpeedInt | RO, LH | 0x0 | 0x0 | Speed Changed 0 = Speed not changed 1 = Speed changed |
| 13 | DuplexInt | RO, LH | 0x0 | 0x0 | Duplex Changed 0 = Duplex not changed 1 = Duplex changed |
| 12 | RxPageInt | RO, LH | 0x0 | 0x0 | 0 = Page not received 1 = Page received |
| 11 | AnegDoneInt | RO, LH | 0x0 | 0x0 | Auto-Negotiation Completed 0 = Auto-Negotiation not completed 1 = Auto-Negotiation completed |
| 10 | LinkInt | RO, LH | 0x0 | 0x0 | Link Status Changed 0 = Link status not changed 1 = Link status changed |
| 9 | SymErrInt | RO, LH | 0x0 | 0x0 | Symbol Error 0 = No symbol error 1 = Symbol error |

**Table 43: PHY Interrupt Status (Continued)
Register 19**

| Bits | Field | Mode | HW Rst | SW Rst | Description |
|------|-------------|--------|-----------|-----------|--|
| 8 | FlsCrslnt | RO, LH | 0x0 | 0x0 | False Carrier 0 = No false carrier 1 = False carrier |
| 7 | FIFOErrInt | RO, LH | 0x0 | 0x0 | FIFO Over /Underflow Error 0 = No over/underflow error 1 = Over/underflow error |
| 6 | MDIMDIXInt | RO, LH | 0x0 | 0x0 | MDI/MDIX Crossover Changed 0 = MDI/MDIX crossover not changed 1 = MDI/MDIX crossover changed |
| 5 | Reserved | RO | Always 0 | Always 0 | Always 0 |
| 4 | EDetChg | RO, LH | 0x0 | 0x0 | Energy Detect Changed 0 = No Change 1 = Changed |
| 3:2 | Reserved | RO | Always 00 | Always 00 | Always 00 |
| 1 | PolarityInt | RO | 0x0 | 0x0 | Polarity Changed 0 = Polarity not changed 1 = Polarity changed |
| 0 | JabberInt | RO, LH | 0x0 | 0x0 | Jabber Mode 0 = No Jabber 1 = Jabber |

**Table 44: PHY Interrupt Port Summary
Register 20**

| Bits | Field | Mode | HW Rst | SW Rst | Description |
|------|----------|------|--------|--------|-------------|
| 15:0 | Reserved | RO | 0x0000 | 0x0000 | |

Table 45: Receive Error Counter Register 21

| Bits | Field | Mode | HW Rst | SW Rst | Description |
|------|----------|------|--------|--------|--|
| 15:0 | RxErrCnt | RO | 0x0000 | 0x0000 | Receive Error Count This register counts receive errors on the media interface. When the maximum receive error count reaches 0xFFFF, the counter will roll over. |

Table 46: LED Parallel Select Register Register 22

| Bits | Field | Mode | HW Rst | SW Rst | Description |
|-------|----------|------|--------|--------|--|
| 15:12 | Reserved | R/W | 0x4 | Retain | |
| 11:8 | LED2 | R/W | 0xA | Retain | LED2 Control. This is a global setting. 0000 = COLX 0001 = ERROR 0010 = DUPLEX 0011 = DUPLEX/COLX 0100 = SPEED 0101 = LINK 0110 = TX 0111 = RX 1000 = ACT 1001 = LINK/RX 1010 = LINK/ACT 1011 = ACT (Blink mode) 1100 = TX (Blink Mode) 1101 = RX (Blink Mode) 1110 = Interrupt 1111 = Force to 1 (inactive) |

**Table 46: LED Parallel Select Register (Continued)
Register 22**

| Bits | Field | Mode | HW Rst | SW Rst | Description |
|------|-------|------|--------|--------|--|
| 7:4 | LED1 | R/W | 0x4 | Retain | LED1 Control. This is a global setting. 0000 = COLX 0001 = ERROR 0010 = DUPLEX 0011 = DUPLEX/COLX 0100 = SPEED 0101 = LINK 0110 = TX 0111 = RX 1000 = ACT 1001 = LINK/RX 1010 = LINK/ACT 1011 = ACT (Blink mode) 1100 = TX (Blink Mode) 1101 = RX (Blink Mode) 1110 = COLX (Blink Mode) 1111 = Force to 1 (inactive) |
| 3:0 | LED0 | R/W | 0x4 | Retain | LED0 Control. This is a global setting. 0000 = COLX 0001 = ERROR 0010 = DUPLEX 0011 = DUPLEX/COLX 0100 = SPEED 0101 = LINK 0110 = TX 0111 = RX 1010 = LINK/ACT 1011 = ACT (Blink mode) 1100 = TX (Blink Mode) 1101 = RX (Blink Mode) 1110 = COLX (Blink Mode) 1111 = Force to 1 (inactive) |

**Table 47: PHY LED Control Register
Register 24**

| Bits | Field | Mode | HW Rst | SW Rst | Description |
|------|----------|------|----------|----------|-------------|
| 15 | Reserved | RO | Always 0 | Always 0 | Must be 0. |

Table 47: PHY LED Control Register (Continued)
Register 24

| Bits | Field | Mode | HW Rst | SW Rst | Description |
|-------|--------------|------|--------|--------|---|
| 14:12 | PulseStretch | R/W | 0x4 | Retain | Pulse stretch duration. This is a global setting. 000 = No pulse stretching 001 = 21 ms to 42 ms 010 = 42 ms to 84 ms 011 = 84 ms to 170 ms 100 = 170 ms to 340 ms 101 = 340 ms to 670 ms 110 = 670 ms to 1.3s 111 = 1.3s to 2.7s |
| 11:9 | BlinkRate | R/W | 0x1 | Retain | Blink Rate. This is a global setting. 000 = 42 ms 001 = 84 ms 010 = 170 ms 011 = 340 ms 100 = 670 ms 101 to 111 = Reserved |
| 8:6 | LED2 Speed | R/W | 0x0 | Retain | LED 2 Speed Select 000 = Active for 10BASE-T Link 001 = Reserved 010 = Reserved 011 = Reserved 100 = Reserved 101 = Active for 100BASE-X 110 = Reserved 111 = Reserved |
| 5:3 | LED1 Speed | R/W | 0x0 | Retain | LED 1 Speed Select 000 = Active for 10BASE-T Link 001 = Reserved 010 = Reserved 011 = Reserved 100 = Reserved 101 = Active for 100BASE-X 110 = Reserved 111 = Reserved |
| 2:0 | LED0 Speed | R/W | 0x5 | Retain | LED 0 Speed Select 000 = Active for 10BASE-T Link 001 = Reserved 010 = Reserved 011 = Reserved 100 = Reserved 101 = Active for 100BASE-X 110 = Reserved 111 = Reserved |

**Table 48: PHY Manual LED Override
Register 25**

| Bits | Field | Mode | HW Rst | SW Rst | Description |
|------|-----------|------|--------|--------|---|
| 15 | Reserved | R/W | 0x0 | Retain | 0 |
| 14 | InvLED2 | R/W | 0x0 | Retain | Invert LED2. This bit controls the active level of the LED2 pin. 0 = Active Low LED2 1 = Active High LED2 |
| 13 | InvLED1 | R/W | 0x0 | Retain | Invert LED1. This bit controls the active level of the LED1 pin. 0 = Active Low LED1 1 = Active High LED1 |
| 12 | InvLED0 | R/W | 0x0 | Retain | Invert LED0. This bit controls the active level of the LED0 pin. 0 = Active Low LED0 1 = Active High LED0 |
| 11:6 | Reserved | R/W | 0x00 | Retain | 000000 |
| 5:4 | ForceLED2 | R/W | 0x0 | Retain | 00 = Normal 01 = Blink[1] 10 = LED Off 11 = LED On |
| 3:2 | ForceLED1 | R/W | 0x0 | Retain | 00 = Normal 01 = Blink 10 = LED Off 11 = LED On |
| 1:0 | ForceLED0 | R/W | 0x0 | Retain | 00 = Normal 01 = Blink 10 = LED Off 11 = LED On |

**Table 49: VCT™ Register for MDIP/N[0] Pins
Register 26**

| Bits | Field | Mode | HW Rst | SW Rst | Description |
|-------|----------|------------|--------|--------|--|
| 15 | EnVCT | R/W, SC | 0x0 | 0x0 | Enable VCT 0 = VCT completed 1 = Run VCT After running VCT once, bit 15 = 0 indicates VCT completed. The cable status is reported in the VCTTst bits in registers 26 and 27. Refer to the Virtual Cable Tester® feature. |
| 14:13 | VCTTst | RO | 0x0 | Retain | VCT Test Status These VCT test status bits are valid after completion of VCT. 00 = Valid test, normal cable (no short or open in cable) 01 = Valid test, short in cable (Impedance < 33 ohm) 10 = Valid test, open in cable (Impedance > 333 ohm) 11 = Test fail |
| 12:8 | AmpRfln | RO | 0x00 | Retain | Amplitude of Reflection The amplitude of reflection is stored in these register bits. These amplitude bits range from 0x07 to 0x1F. 0x1F = Maximum positive amplitude 0x13 = Zero amplitude 0x07 = Maximum negative amplitude These bits are valid after completion of VCT (bit 15) and if the VCT test status bits (bits 14:13) have not indicated test failure. |
| 7:0 | DistRfln | RO | 0x00 | Retain | Distance of Reflection These bits refer to the approximate distance (± 1 m) to the open/short location, measured at nominal conditions (room temperature and typical VDDs) These bits are valid after completion of VCT (bit 15) and if the VCT test status bits (bit 14:13) have not indicated test failure. |

**Table 50: VCT™ Register for MDIP/N[1] Pins
Register 27**

| Bits | Field | Mode | HW Rst | SW Rst | Description |
|-------|----------|------|----------|----------|---|
| 15 | Reserved | RO | Always 0 | Always 0 | Reserved |
| 14:13 | VCTTst | RO | 0x0 | Retain | VCT Test Status The VCT test status bits are valid after completion of VCT. 00 = Valid test, normal cable (no short or open in cable) 01 = Valid test, short in cable (Impedance < 33 ohm) 10 = Valid test, open in cable (Impedance > 333 ohm) 11 = Test fail |
| 12:8 | AmpRfln | RO | 0x00 | Retain | Amplitude of Reflection The amplitude of reflection is stored in these register bits. These amplitude bits range from 0x07 to 0x1F. 0x1F = Maximum positive amplitude 0x13 = Zero amplitude 0x07 = Maximum negative amplitude These bits are valid after completion of VCT (bit 15) and if VCT test status bits (bit 14:13) have not indicated test failure. |
| 7:0 | DistRfln | RO | 0x00 | Retain | Distance of Reflection These bits refer to the approximate distance ($\pm 1m$) to the open/short location, measured at nominal conditions (room temperature and typical VDDs) These bits are valid after completion of VCT (bit 15) and if VCT test status bits (bits 14:13) have not indicated test failure. |

**Table 51: PHY Specific Control Register II
Register 28**

| Bits | Field | Mode | HW Rst | SW Rst | Description |
|-------|----------------------|------|-----------|--------|---|
| 15:12 | Reserved | R/W | 0x0 | Retain | Must be 0000 |
| 11:10 | MAC Interface Mode | R/W | See Desc. | Update | During Hardware Reset register 28.11:10 defaults as follows: MODE[2:0] 28.11:10 000 00 001 01 010 00 111 01 00 = RGMII where receive clock transition when data transitions 01 = RGMII where receive clock transition when data stable 10 = Reserved 11 = Reserved |
| 9:5 | Reserved | R/W | 0x00 | Update | Set to 00000 |
| 4 | EnLineLpbk | R/W | 0x0 | Retain | 0 = Disable Line Loopback 1 = Enable Line Loopback |
| 3 | SoftwareMedia Select | R/W | See Desc. | Update | During Hardware Reset register 28.3 defaults as follows MODE[2:0] 28.3 000 0 001 0 010 1 011 0 100 1 110 0 111 1 0 = Select Copper Media 1 = Select Fiber Media |
| 2 | TDRWaitTime | R/W | 0x0 | Retain | 0 = Wait time is 1.5s before TDR test is started 1 = Wait time is 25ms before TDR test is started |
| 1 | EnRXCLK | R/W | 0x1 | Update | 0 = Disable MAC interface clock (RXCLK) in sleep mode 1 = Enable MAC interface clock (RXCLK) in sleep mode |
| 0 | SelClsA | R/W | 0x0 | Update | 0 = Select Class B driver (typically used in CAT 5 applications) 1 = Select Class A driver - available for 100BASE-TX mode only (typically used in Backplane or direct connect applications, but may be used with CAT 5 applications) |

**Table 52: Test Mode Select
Register 29**

| Bits | Field | Mode | HW Rst | SW Rst | Description |
|------|----------|------|--------|--------|---------------------|
| 15:5 | Reserved | R/W | 0x000 | Retain | Must set to all 0s. |
| 4:0 | Page | R/W | 0x00 | Retain | Register 30 Page |

**Table 53: CRC Status Register
Register 30_9**

| Bits | Field | Mode | HW Rst | SW Rst | Description |
|------|-----------------|------|----------|--------|--|
| 15:8 | CRC Error Count | RO | 0x00 | Retain | Represents the CRC Error count for received packets since 30_9.0 is set |
| 7:1 | Reserved | R/W | Always 0 | 0x00 | 0000000 |
| 0 | CRC Enable | R/W | 0x0 | Retain | 1=Enable CRC checker for all ports. 0=Disable CRC checker for all ports |

**Table 54: RGMII Output Impedance Calibration Override
Register 30_10**

| Bits | Field | Mode | HW Rst | SW Rst | Description |
|------|----------------------|---------|-----------|--------|--|
| 15 | Restart Calibration | R/W, SC | 0x0 | Retain | Calibration will start once bit 15 is set to 1. 0 = Normal 1 = Restart |
| 14 | Calibration Complete | RO | 0x0 | Retain | Calibration is done once bit 14 becomes 1. 0 = Not done 1 = Done |
| 13 | Reserved | R/W | 0x0 | Retain | 0 |
| 12:8 | PMOS Value | R/W | See Descr | Retain | 00000 = All fingers off 11111 = All fingers on The automatic calibrated values are stored here after calibration completes. Once LATCH is set to 1 the new calibration value is written into the I/O pad. The automatic calibrated value is lost. |
| 7 | Reserved | RW | 0x0 | Retain | 0 |
| 6 | LATCH | R/W, SC | 0x0 | Retain | 1 = Latch in new value. This bit self clears. (Used for manual settings) |
| 5 | PMOS/NMOS Select | R/W | 0x0 | Retain | 0 = NMOS value written when LATCH is set to 1. 1 = PMOS value written when LATCH is set to 1. |
| 4:0 | NMOS value | R/W | See Descr | Retain | 00000 = All fingers off 11111 = All fingers on The automatic calibrated values are stored here after calibration completes. Once LATCH is set to 1 the new calibration value is written into the I/O pad. The automatic calibrated value is lost. |

Table 55: RGMII Output Impedance Target Register 30_11

| Bits | Field | Mode | HW Rst | SW Rst | Description |
|------|-----------------------------------|------|--------|--------|--|
| 15:7 | Reserved | RO | 0x000 | 0x000 | 000000000 |
| 6:4 | Calibration PMOS Target Impedance | RW | 0x4 | Retain | 000 = 80 Ohm 001 = 69 Ohm 010 = 61 Ohm 011 = 54 Ohm 100 = 49 Ohm 101 = 44 Ohm 110 = 41 Ohm 111 = 38 Ohm |
| 3 | Reserved | RO | 0x0 | 0x0 | 0 |
| 2:0 | Calibration NMOS Target Impedance | RW | 0x4 | Retain | 000 = 80 Ohm 001 = 69 Ohm 010 = 61 Ohm 011 = 54 Ohm 100 = 49 Ohm 101 = 44 Ohm 110 = 41 Ohm 111 = 38 Ohm |

Section 4. Electrical Specifications

4.1. Absolute Maximum Ratings

Stresses above those listed in Absolute Maximum Ratings may cause permanent device failure. Functionality at or above these limits is not implied. Exposure to absolute maximum ratings for extended periods may affect device reliability.

| Symbol | Parameter | Min | Typ | Max | Units |
|----------------------|---|------|-----|----------------------------------|-------|
| V _{DDA} | Power Supply Voltage on AVDD with respect to VSS | -0.5 | | 3.6 | V |
| V _{DDAC} | Power Supply Voltage on AVDDC with respect to VSS | -0.5 | | 3.6 | V |
| V _{DDAR} | Power Supply Voltage on AVDDR with respect to VSS | -0.5 | | 3.6 | V |
| V _{DDAX} | Power Supply Voltage on AVDDX with respect to VSS | -0.5 | | 3.6 | V |
| V _{DD} | Power Supply Voltage on VDD with respect to VSS | -0.5 | | 3.6 | V |
| V _{DDO} | Power Supply Voltage on VDDO with respect to VSS | -0.5 | | 3.6 | V |
| V _{DDOR} | Power Supply Voltage on VDDOR with respect to VSS | -0.5 | | 3.6 | V |
| V _{PIN} | Voltage applied to any digital input pin | -0.5 | | VDDO(R) + 0.7, whichever is less | V |
| T _{STORAGE} | Storage temperature | -55 | | +125 ¹ | °C |

1. 125 °C is only used as bake temperature for not more than 24 hours. Long term storage (e.g weeks or longer) should be kept at 85 °C or lower.

4.2. Recommended Operating Conditions

| Symbol | Parameter | Condition | Min | Typ | Max | Units |
|--------------|--|--------------------------------|------|------|------------------|--------------------|
| V_{DDA}^1 | AVDD supply | For AVDD | 2.38 | 2.5 | 2.62 | V |
| V_{DDAC}^1 | AVDDC supply | For AVDDC at 2.5V | 2.38 | 2.5 | 2.62 | V |
| | | For AVDDC at 3.3V | 3.14 | 3.3 | 3.46 | V |
| V_{DDAR}^1 | AVDDR supply | For AVDDR | 2.38 | 2.5 | 2.62 | V |
| V_{DDAX}^1 | AVDDX supply | For AVDDX at 3.3V | 3.14 | 3.3 | 3.46 | V |
| V_{DD}^1 | DVDD supply | For DVDD | 1.14 | 1.2 | 1.26 | V |
| V_{DDO}^1 | VDDO supply | For VDDO at 2.5V | 2.38 | 2.5 | 2.62 | V |
| | | For VDDO at 3.3V | 3.14 | 3.3 | 3.46 | V |
| V_{DDOR}^1 | VDDOR supply | For VDDOR at 2.5V | 2.38 | 2.5 | 2.62 | V |
| | | For VDDOR at 3.3V | 3.14 | 3.3 | 3.46 | V |
| RSET | Internal bias reference | Resistor connected to V_{SS} | 1980 | 2000 | 2020 | Ω |
| T_A | Commercial Ambient operating temperature | | 0 | | 70 ² | $^{\circ}\text{C}$ |
| T_J | Maximum junction temperature | | | | 125 ³ | $^{\circ}\text{C}$ |

1. Maximum noise allowed on supplies is 50 mV peak-peak.

2. Commercial operating temperatures are typically below 70 $^{\circ}\text{C}$, e.g. 45 $^{\circ}\text{C}$ ~55 $^{\circ}\text{C}$. The 70 $^{\circ}\text{C}$ max is Marvell[®] specification limit

3. Refer to white paper on TJ Thermal Calculations for more information.

4.3 Package Thermal Information

4.3.1 88E3016 Device 64-Pin QFN package

| Symbol | Parameter | Condition | Min | Typ | Max | Units |
|---------------|--|---|-----|-------|-----|-------|
| θ_{JA} | Thermal resistance - junction to ambient of the 64-Pin QFN package $\theta_{JA} = (T_J - T_A) / P$ P = Total Power Dissipation | JEDEC 3 in. x 4.5 in. 4-layer PCB with no air flow | | 32.40 | | °C/W |
| | | JEDEC 3 in. x 4.5 in. 4-layer PCB with 1 meter/sec air flow | | 28.60 | | °C/W |
| | | JEDEC 3 in. x 4.5 in. 4-layer PCB with 2 meter/sec air flow | | 27.40 | | °C/W |
| | | JEDEC 3 in. x 4.5 in. 4-layer PCB with 3 meter/sec air flow | | 26.70 | | °C/W |
| ψ_{JT} | Thermal characteristic parameter ¹ - junction to top center of the 64-Pin QFN package $\psi_{JT} = (T_J - T_C) / P$ P = Total Power Dissipation | JEDEC 3 in. x 4.5 in. 4-layer PCB with no air flow | | 0.52 | | °C/W |
| | | JEDEC 3 in. x 4.5 in. 4-layer PCB with 1 meter/sec air flow | | 0.89 | | °C/W |
| | | JEDEC 3 in. x 4.5 in. 4-layer PCB with 2 meter/sec air flow | | 1.12 | | °C/W |
| | | JEDEC 3 in. x 4.5 in. 4-layer PCB with 3 meter/sec air flow | | 1.26 | | °C/W |
| θ_{JC} | Thermal resistance ¹ - junction to case for the 64-Pin QFN package $\theta_{JC} = (T_J - T_C) / P_{Top}$ P _{Top} = Power Dissipation from the top of the package | JEDEC with no air flow | | 17.30 | | °C/W |
| θ_{JB} | Thermal resistance ¹ - junction to board for the 64-Pin QFN package $\theta_{JB} = (T_J - T_B) / P_{bottom}$ P _{bottom} = power dissipation from the bottom of the package to the PCB surface. | JEDEC with no air flow | | 21.10 | | °C/W |

1. Refer to white paper TJ Thermal Calculations for more information.

4.4 Current Consumption



Note

The following current consumption numbers are shown when external supplies are used. If internal regulators are used, the current consumption will not change; however, the power consumed inside the package will increase.

4.4.1 Current Consumption AVDD + Center Tap

(Over full range of values listed in the Recommended Operating Conditions unless otherwise specified)

| Symbol | Parameter | Pins | Condition | Min | Typ ^{1,2} | Max | Units |
|------------------|---------------------------------------|------|---------------------------------|-----|--------------------|-----|-------|
| I _{DDA} | 2.5V Power to analog core, analog I/O | AVDD | 10BASE-T idle | | 25 | | mA |
| | | | 10BASE-T with traffic | | 90 | | mA |
| | | | 100BASE-TX with traffic or idle | | 54 | | mA |
| | | | Auto-Negotiation with no link | | 25 | | mA |
| | | | 100BASE-FX with traffic or idle | | 57 | | mA |
| | | | COMA | | 7 | | mA |
| | | | Sleep (Energy Detect+™) | | 25 | | mA |
| | | | Power Down | | 7 | | mA |

1. The values listed are typical values with three LEDs and Auto-Negotiation on.
2. If the 2.5V PNP option is used, then this current is consumed by AVDDX.

4.4.2 Current Consumption AVDDC

(Over full range of values listed in the Recommended Operating Conditions unless otherwise specified)

| Symbol | Parameter | Pins | Condition | Min | Typ ¹ | Max | Units |
|------------------|--------------------------------|-------|---------------------------------|-----|------------------|-----|-------|
| I _{DDC} | 2.5V/3.3V Power to analog core | AVDDC | 10BASE-T idle | | 5 | | mA |
| | | | 10BASE-T with traffic | | 5 | | mA |
| | | | 100BASE-TX with traffic or idle | | 5 | | mA |
| | | | Auto-Negotiation with no link | | 5 | | mA |
| | | | 100BASE-FX with traffic or idle | | 4 | | mA |
| | | | COMA | | 4 | | mA |
| | | | Sleep (Energy Detect+™) | | 4 | | mA |
| | | | Power Down | | 4 | | mA |

1. The values listed are typical values with three LEDs and Auto-Negotiation on.



Note

The following current consumption numbers are shown when external supplies are used. If internal regulators are used, the current consumption will not change; however, the power consumed inside the package will increase.

4.4.3 Current Consumption DVDD

(Over full range of values listed in the Recommended Operating Conditions unless otherwise specified)

| Symbol | Parameter | Pins | Condition | Min | Typ ^{1,2} | Max | Units |
|-----------------|---------------------------|------|---------------------------------|-----|--------------------|-----|-------|
| I _{DD} | 1.2V Power to digital I/O | DVDD | 10BASE-T idle | | 7 | | mA |
| | | | 10BASE-T with traffic | | 8 | | mA |
| | | | 100BASE-TX with traffic or idle | | 25 | | mA |
| | | | Auto-Negotiation with no link | | 7 | | mA |
| | | | 100BASE-FX with traffic or idle | | 11 | | mA |
| | | | COMA | | 4 | | mA |
| | | | Sleep (Energy Detect+™) | | 8 | | mA |
| | | | Power Down | | 4 | | mA |

1. The values listed are typical values with three LEDs and Auto-Negotiation on.
2. If the internal 1.2V regulator is used, the DVDD current is consumed by AVDDR.

4.4.4 Current Consumption VDDO + VDDOR

(Over full range of values listed in the Recommended Operating Conditions unless otherwise specified)

| Symbol | Parameter | Pins | Condition | Min | Typ ¹ | Max | Units |
|------------------|---|------|---------------------------------|-----|------------------|-----|-------|
| I _{DDO} | 2.5V/3.3V non-RGMII digital I/O and RGMII digital I/O | VDDO | 10BASE-T idle | | 1 | | mA |
| | | | 10BASE-T with traffic | | 5 | | mA |
| | | | 100BASE-TX with traffic or idle | | 8 | | mA |
| | | | Auto-Negotiation with no link | | 1 | | mA |
| | | | 100BASE-FX with traffic or idle | | 9 | | mA |
| | | | COMA | | 3 | | mA |
| | | | Sleep (Energy Detect+™) | | 1 | | mA |
| | | | Power Down | | 2 | | mA |

1. The values listed are typical values with three LEDs and Auto-Negotiation on.

4.5. DC Operating Conditions

4.5.1 Non-RGMII Digital Pins

(Over full range of values listed in the Recommended Operating Conditions unless otherwise specified)

| Symbol | Parameter | Pins ¹ | Condition | Min | Typ | Max | Units |
|------------------|---------------------------|--------------------------------|-------------|-------------|-----|-----------|-------|
| VIH | Input high voltage | All digital inputs | VDDO = 3.3V | 2.31 | | | V |
| | | | VDDO = 2.5V | 1.75 | | | V |
| VIL | Input low voltage | All digital inputs | VDDO = 3.3V | | | 0.99 | V |
| | | | VDDO = 2.5V | | | 0.75 | V |
| VOH | High level output voltage | All digital outputs | IOH = -4 mA | VDDO - 0.4V | | | V |
| VOL | Low level output voltage | All digital outputs | IOL = 4 mA | | | 0.4 | V |
| I _{ILK} | Input leakage current | With internal pull-up resistor | | | | 10 -50 | uA |
| | | All others without resistor | | | | 10 | uA |
| CIN | Input capacitance | All pins | | | | 5 | pF |

1. VDDO supplies the SIGDET, MDC, MDIO, RESE_{Tn}, LED[2:0], CONFIG[3:0], TDI, TMS, TCK, TRST_n, TDO, COMA_n, DIS_REG12, CTRL25, HSDAC, and TSTPT pins.

Table 56: 88E3016 Device Internal Resistor Description

| 88E3016 Device Pin # | Pin Name | Resistor |
|----------------------|-------------------|------------------|
| 13 | TCK | Internal pull-up |
| 14 | TMS | Internal pull-up |
| 37 | TRST _n | Internal pull-up |
| 12 | TDI | Internal pull-up |
| 4 | COMA _n | Internal pull-up |

4.5.2 Stub-Series Transceiver Logic (SSTL_2)

Figure 12: SSTL_2 Termination Circuit

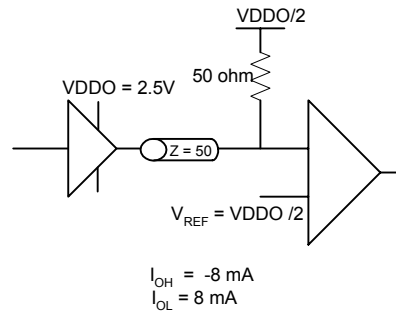

Note

This circuit can be used if termination is required. This circuit can also be used unterminated if the interconnect is short.

Figure 13: SSTL_2 Input Voltage Levels

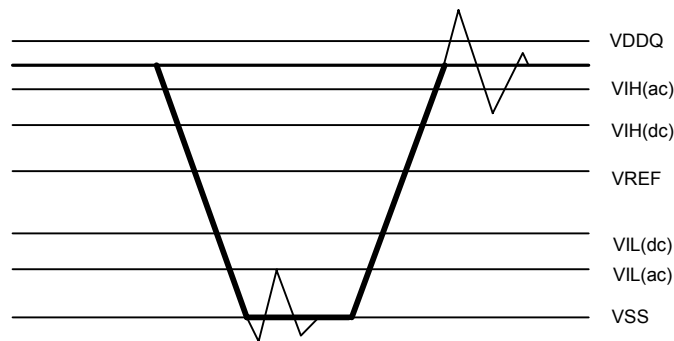

Table 57: Reference I/O Parameters¹

| Parameter | Description | Corner | 2.5V SSTL_2 | 3.3V SSTL_2 | Units |
|-----------|----------------------------------|--------|----------------|----------------|-------|
| VDDQ | Output Supply Voltage | min | 2.38 | 3.14 | V |
| | | nom | 2.5 | 3.3 | V |
| | | max | 2.62 | 3.46 | V |
| VREF | Input Reference Voltage | min | 1.19 | 1.57 | V |
| | | nom | 1.25 | 1.65 | V |
| | | max | 1.31 | 1.73 | V |
| VTT | Termination Voltage | min | VREF - 0.04 | | V |
| | | nom | VREF | | V |
| | | max | VREF + 0.04 | | V |
| VIH(dc) | DC Input Logic High | min | VREF + 0.18 | VREF + 0.25 | V |
| | | max | VDDQ + 0.30 | VDDQ + 0.30 | V |
| VIL(dc) | DC Input Logic Low | min | - 0.30 | - 0.30 | V |
| | | max | VREF - 0.18 | VREF - 0.25 | V |
| VIH(ac) | AC Input Logic High | min | VREF + 0.35 | VREF + 0.50 | V |
| | | max | -- | -- | V |
| VIL(ac) | AC Input Logic Low | min | -- | -- | V |
| | | max | VREF - 0.35 | VREF - 0.50 | V |
| VOH(dc) | DC Output Logic High | min | | | V |
| | | max | | | V |
| VOL(dc) | DC Output Logic Low | min | | | V |
| | | max | | | V |
| VOH(ac) | AC Output Logic High | min | VTT + 0.57 | VTT + 0.9 | V |
| | | max | -- | | V |
| VOL(ac) | AC Output Logic Low | min | -- | | V |
| | | max | VTT - 0.57 | VTT - 0.9 | V |
| IOH(dc) | Output Minimum Source DC Current | min | 7.60 | 7.60 | mA |
| | | max | -- | -- | mA |
| IOL(dc) | Output Minimum Sink DC Current | min | 7.60 | 7.60 | mA |
| | | max | -- | -- | mA |
| | Input Timing Reference Level | | VREF | VREF | V |
| | Input Signal Swing | | 1.5 | 2.0 | V |
| | Input Signal Edge Rate | | ± 1.0 | ± 1.0 | V/ns |
| | Output Timing Reference Level | | VDDQ/2 | VDDQ/2 | V |

1. These numbers are preliminary. Marvell® reserves the right to change these parameters.

4.5.3 IEEE DC Transceiver Parameters

IEEE tests are typically based on template and cannot simply be specified by a number. For an exact description of the template and the test conditions, refer to the IEEE specifications.

- 10BASE-T IEEE 802.3 Clause 14
- 100BASE-TX ANSI X3.263-1995

(Over full range of values listed in the Recommended Operating Conditions unless otherwise specified)

| Symbol | Parameter | Pins | Condition | Min | Typ | Max | Units |
|--------------------|--|------------------------|----------------------|------------------|------------------|-------|--------------|
| V _{ODIFF} | Absolute peak differential output voltage | MDIP/N[0] MDIP/N[1] | 10BASE-T no cable | 2.2 | 2.5 | 2.8 | V |
| | | MDIP/N[0] MDIP/N[1] | 10BASE-T cable model | 585 ¹ | | | mV |
| | | MDIP/N[0] MDIP/N[1] | 100BASE-FX mode | 0.4 | 0.8 | 1.2 | V |
| | | MDIP/N[0] MDIP/N[1] | 100BASE-TX mode | 0.950 | 1.0 | 1.05 | V |
| | Overshoot | MDIP/N[0] MDIP/N[1] | 100BASE-TX mode | 0 | | 5% | V |
| | Amplitude symmetry (P/N) | MDIP/N[0] MDIP/N[1] | 100BASE-TX mode | 0.98x | | 1.02x | V+/- |
| V _{IDIFF} | Peak differential input voltage accept level | MDIP/N[0] MDIP/N[1] | 10BASE-T mode | 585 ² | | | mV |
| | | MDIP/N[0] MDIP/N[1] | 100BASE-FX mode | 200 | | | mV |
| | Peak differential input voltage reject level | MDIP/N[0] MDIP/N[1] | 100BASE-FX mode | 100 | | | mV |
| | Signal detect assertion | MDIP/N[0] MDIP/N[1] | 100BASE-TX mode | 1000 | 460 ³ | | mV peak-peak |
| | Signal detect de-assertion | MDIP/N[0] MDIP/N[1] | 100BASE-TX mode | 200 | 360 ⁴ | | mV peak-peak |

1. IEEE 802.3 Clause 14-2000, Figure 14.9 shows the template for the “far end” wave form. This template allows as little as 495 mV peak differential voltage at the far end receiver.
2. The input test is actually a template test, IEEE 802.3 Clause 14-2000. Figure 14.17 shows the template for the receive wave form.
3. The ANSI TP-PMD specification requires that any received signal with peak-to-peak differential amplitude greater than 1000 mV should turn on signal detect (internal signal in 100BASE-TX mode). The will accept signals typically with 460 mV peak-to-peak differential amplitude.
4. The ANSI TP-PMD specification requires that any received signal with peak-to-peak differential amplitude less than 200 mV should be de-assert signal detect (internal signal in 100BASE-TX mode). The will reject signals typically with peak-to-peak differential amplitude less than 360 mV.

4.6 AC Electrical Specifications

4.6.1 Reset and Configuration Timing

(Over full range of values listed in the Recommended Operating Conditions unless otherwise specified)

| Symbol | Parameter | Condition | Min | Typ | Max | Units |
|-----------------|---|-----------|-----|-----|-----|-------|
| T_{PU_RESET} | Power up to hardware de-asserted | | 10 | | | ms |
| T_{SU_CLK} | Number of valid REFCLK cycles prior to RESETn de-asserted | | 10 | | | clks |

Figure 14: Reset Timing

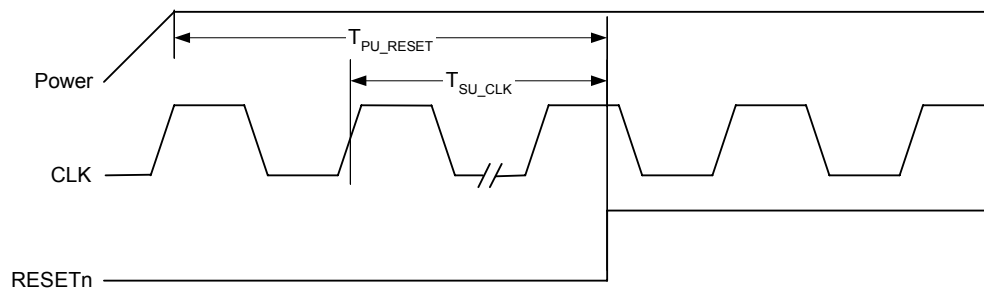

4.6.2 XTAL_IN Input Clock Timing¹

(Over full range of values listed in the Recommended Operating Conditions unless otherwise specified)

| Symbol | Parameter | Condition | Min | Typ | Max | Units |
|-------------------|-----------------------------------|---|---------------|-----|---------------|-----------------|
| $T_{P_XTAL_IN}$ | XTAL_IN Period | 25 MHz | 40 -50 ppm | 40 | 40 +50 ppm | ns |
| $T_{H_XTAL_IN}$ | XTAL_IN High time | 25 MHz | 14 | 20 | 26 | ns |
| $T_{L_XTAL_IN}$ | XTAL_IN Low time | 25 MHz | 14 | 20 | 26 | ns |
| $T_{R_XTAL_IN}$ | XTAL_IN Rise | $V_{IL(max)}$ to $V_{IH(min)}$ - 25 MHz | - | 3.0 | - | ns |
| $T_{F_XTAL_IN}$ | XTAL_IN Fall | $V_{IH(min)}$ to $V_{IL(max)}$ - 25 MHz | - | 3.0 | - | ns |
| $T_{J_XTAL_IN}$ | XTAL_IN total jitter ² | 25 MHz | - | - | 200 | ps ³ |

1. If the crystal option is used, ensure that the frequency is 25 MHz \pm 50 ppm. Capacitors must be chosen carefully - see application note supplied by the crystal vendor.
2. PLL generated clocks are not recommended as input to XTAL_IN since they can have excessive jitter. Zero delay buffers are also not recommended for the same reason.
3. Broadband peak-peak = 200 ps, Broadband rms = 3 ps, 12 kHz to 20 MHz rms = 1 ps.

Figure 15: Clock Timing

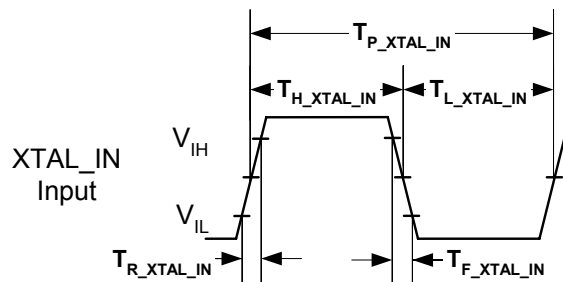

4.7 RGMII Interface Timing

4.7.1 RGMII Transmit Timing

4.7.1.1 100 Mbps RGMII Transmit Timing

(Over full range of values listed in the Recommended Operating Conditions unless otherwise specified)

| Symbol | Parameter | Condition | Min | Typ | Max | Units |
|--------------------------|------------------|-----------|-----|-----|-----|-------|
| $T_{SU_RGMII_TX_CLK}$ | RGMII Setup Time | | 1.0 | | | ns |
| $T_{HD_RGMII_TX_CLK}$ | RGMII Hold Time | | 0.8 | | | ns |
| $T_{H_RGMII_TX_CLK}$ | TX_CLK High | | 10 | 20 | 30 | ns |
| $T_{L_RGMII_TX_CLK}$ | TX_CLK Low | | 10 | 20 | 30 | ns |
| $T_{P_RGMII_TX_CLK}$ | TX_CLK Period | | | 40 | | ns |

4.7.1.2 10 Mbps RGMII Transmit Timing

(Over full range of values listed in the Recommended Operating Conditions unless otherwise specified)

| Symbol | Parameter | Condition | Min | Typ | Max | Units |
|--------------------------|------------------|-----------|-----|-----|-----|-------|
| $T_{SU_RGMII_TX_CLK}$ | RGMII Setup Time | | 1.0 | | | ns |
| $T_{HD_RGMII_TX_CLK}$ | RGMII Hold Time | | 0.8 | | | ns |
| $T_{H_RGMII_TX_CLK}$ | TX_CLK High | | 100 | 200 | 300 | ns |
| $T_{L_RGMII_TX_CLK}$ | TX_CLK Low | | 100 | 200 | 300 | ns |
| $T_{P_RGMII_TX_CLK}$ | TX_CLK Period | | | 400 | | ns |

Figure 16: RGMII Transmit Timing

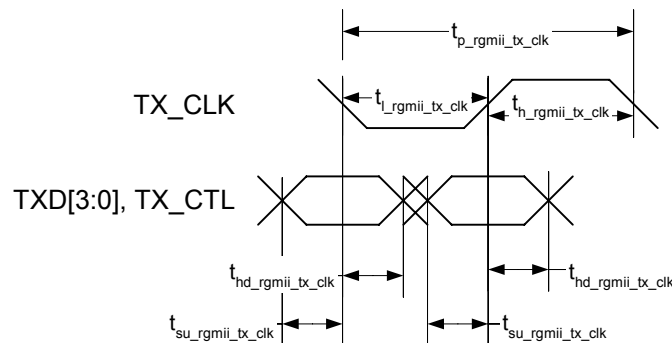

4.7.2 RGMII Receive Timing

4.7.2.1 Register 28.11:10 = 00

(Over full range of values listed in the Recommended Operating Conditions unless otherwise specified)

| Symbol | Parameter | Min | Typ | Max | Units |
|------------|------------|-------|-----|-----|-------|
| t_{skew} | All speeds | - 0.5 | | 0.5 | ns |

Figure 17: RGMII RX_CLK Delay Timing - Register 28.11:10 = 00

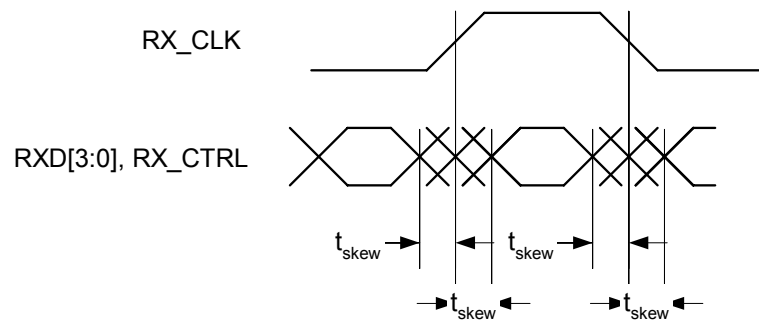

4.7.2.2 Register 28.11:10 = 01

100 Mbps RGMII Receive Timing

(Over full range of values listed in the Recommended Operating Conditions unless otherwise specified)

| Symbol | Parameter | Condition | Min | Typ | Max | Units |
|--------------------------|-----------------------|-----------|-----|-----|-----|-------|
| $T_{SU_RGMII_RX_CLK}$ | RGMII Output to Clock | | 5 | | | ns |
| $T_{HD_RGMII_RX_CLK}$ | RGMII Clock to Output | | 5 | | | ns |
| $T_{H_RGMII_RX_CLK}$ | RX_CLK High | | 18 | 20 | 22 | ns |
| $T_{L_RGMII_RX_CLK}$ | RX_CLK Low | | 18 | 20 | 22 | ns |
| $T_{P_RGMII_RX_CLK}$ | RX_CLK Period | | | 40 | | ns |

10 Mbps RGMII Receive Timing

(Over full range of values listed in the Recommended Operating Conditions unless otherwise specified)

| Symbol | Parameter | Condition | Min | Typ | Max | Units |
|--------------------------|-----------------------|-----------|-----|-----|-----|-------|
| $T_{SU_RGMII_RX_CLK}$ | RGMII Output to Clock | | 80 | | | ns |
| $T_{HD_RGMII_RX_CLK}$ | RGMII Clock to Output | | 80 | | | ns |
| $T_{H_RGMII_RX_CLK}$ | RX_CLK High | | 190 | 200 | 210 | ns |
| $T_{L_RGMII_RX_CLK}$ | RX_CLK Low | | 190 | 200 | 210 | ns |
| $T_{P_RGMII_RX_CLK}$ | RX_CLK Period | | | 400 | | ns |

Figure 18: RGMII RX_CLK Delay Timing - Register 28.11:10 = 01 (add delay)

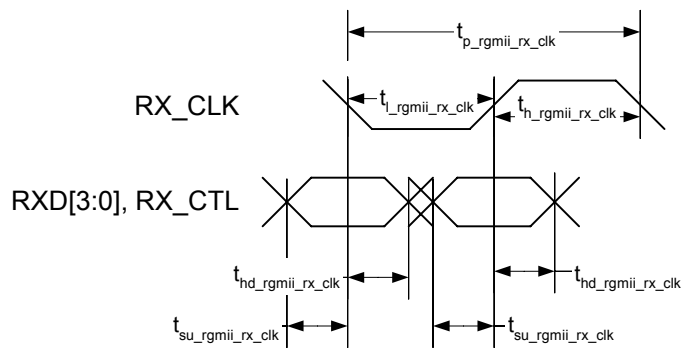

4.8 Latency Timing

4.8.1 RGMII to 100BASE-TX Transmit Latency Timing

(Over full range of values listed in the Recommended Operating Conditions unless otherwise specified)

| Symbol | Parameter | Condition | Min | Typ | Max | Units |
|-------------------------|---------------------------------------|-----------|-----|-----|-----|-------|
| $T_{AS_TXC_MDI_100}$ | 100BASE-TX TX_CTRL Asserted to /J/ | | 248 | | 274 | ns |
| $T_{DA_TXC_MDI_100}$ | 100BASE-TX TX_CTRL De-asserted to /T/ | | 248 | | 274 | ns |

4.8.2 RGMII to 10BASE-T Transmit Latency Timing

(Over full range of values listed in the Recommended Operating Conditions unless otherwise specified)

| Symbol | Parameter | Condition | Min | Typ | Max | Units |
|------------------------|---------------------------------------|-----------|------|-----|------|-------|
| $T_{AS_TXC_MDI_10}$ | 10BASE-T TX_CTRL Asserted to Preamble | | 2245 | | 2360 | ns |
| $T_{DA_TXC_MDI_10}$ | 10BASE-T TX_CTRL De-asserted to ETD | | 2245 | | 2360 | ns |

Figure 19: RGMII to 10/100 Transmit Latency Timing

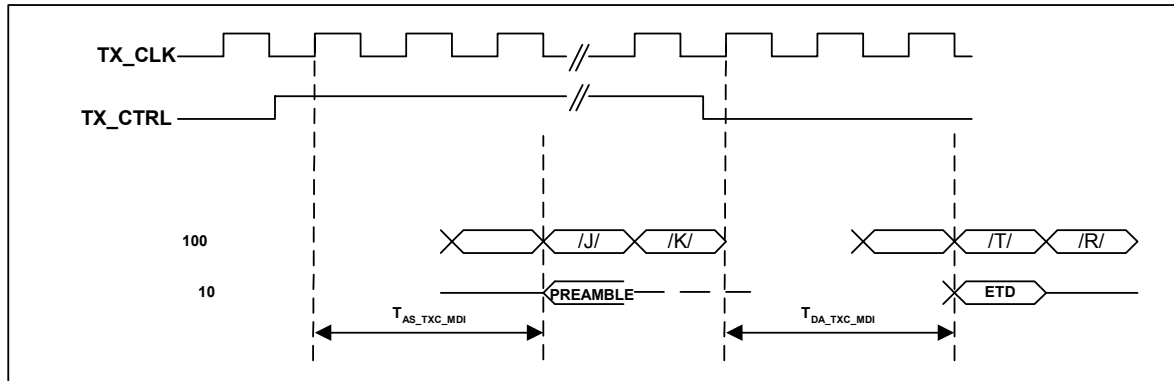

4.8.3 100BASE-TX to RGMII Receive Latency Timing

(Over full range of values listed in the Recommended Operating Conditions unless otherwise specified)

| Symbol | Parameter | Condition | Min | Typ | Max | Units |
|-------------------------|--|-----------|-----|-----|-----|-------|
| $T_{AS_MDI_RXC_100}$ | 100BASE-TX MDI start of Packet to RX_CTRL Asserted | | 231 | | 297 | ns |
| $T_{DA_MDI_RXC_100}$ | 100BASE-TX MDI /T/ to RX_CTRL De-asserted | | 231 | | 297 | ns |

4.8.4 10BASE-T to RGMII Receive Latency Timing

(Over full range of values listed in the Recommended Operating Conditions unless otherwise specified)

| Symbol | Parameter | Condition | Min | Typ | Max | Units |
|------------------------|--|-----------|------|-----|------|-------|
| $T_{AS_MDI_RXC_10}$ | 10BASE-T MDI start of Packet to RX_CTRL Asserted | | 1300 | | 1910 | ns |
| $T_{DA_MDI_RXC_10}$ | 10BASE-T MDI ETD to RX_CTRL De-asserted | | 1300 | | 1910 | ns |

Figure 20: 10/100 to RGMII Receive Latency Timing

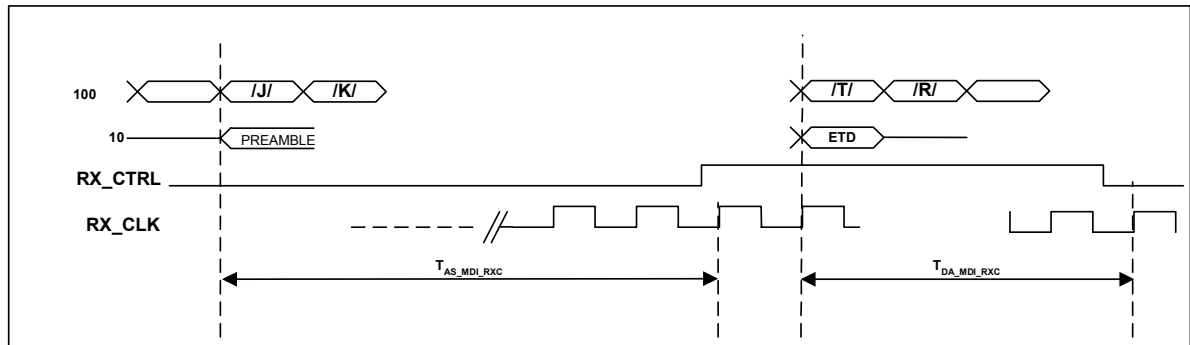

4.9 Serial Management Timing

(Over full range of values listed in the Recommended Operating Conditions unless otherwise specified)

| Symbol | Parameter | Condition | Min | Typ | Max | Units |
|-----------------|---------------------------------|-----------|-----|-----|-----|-------|
| T_{DLY_MDIO} | MDC to MDIO (Output) Delay Time | | 0 | | 25 | ns |
| T_{SU_MDIO} | MDIO (Input) to MDC Setup Time | | 10 | | | ns |
| T_{HD_MDIO} | MDIO (Input) to MDC Hold Time | | 10 | | | ns |
| T_{P_MDC} | MDC Period | | 120 | | | ns |
| T_{H_MDC} | MDC High | | 30 | | | ns |
| T_{L_MDC} | MDC Low | | 30 | | | ns |

Figure 21: Serial Management Timing

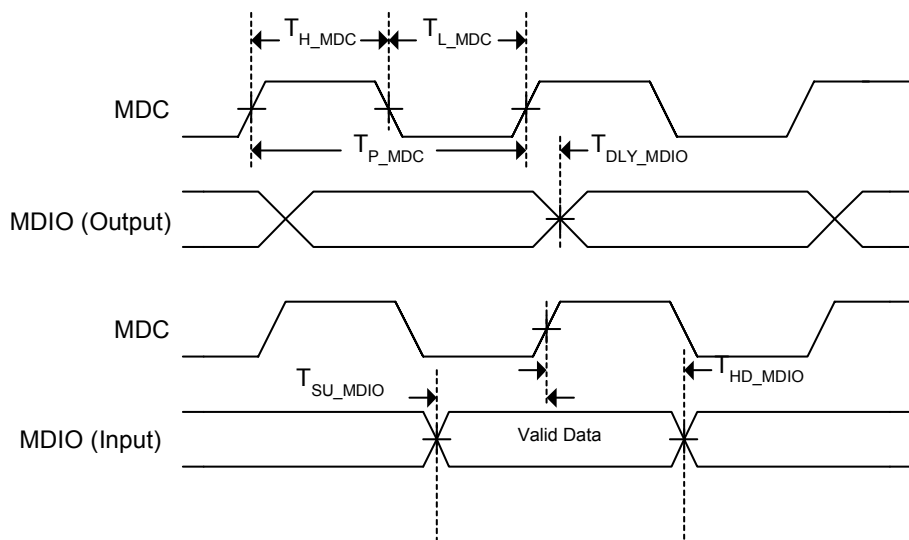

4.10 JTAG Timing

(Over full range of values listed in the Recommended Operating Conditions unless otherwise specified)

| Symbol | Parameter | Condition | Min | Typ | Max | Units |
|----------------|----------------------------|-----------|-----|-----|-----|-------|
| T_{P_TCK} | TCK Period | | 40 | | | ns |
| T_{H_TCK} | TCK High | | 12 | | | ns |
| T_{L_TCK} | TCK Low | | 12 | | | ns |
| T_{SU_TDI} | TDI, TMS to TCK Setup Time | | 10 | | | ns |
| T_{HD_TDI} | TDI, TMS to TCK Hold Time | | 10 | | | ns |
| T_{DLY_TDO} | TCK to TDO Delay | | 0 | | 20 | ns |

Figure 22: JTAG Timing

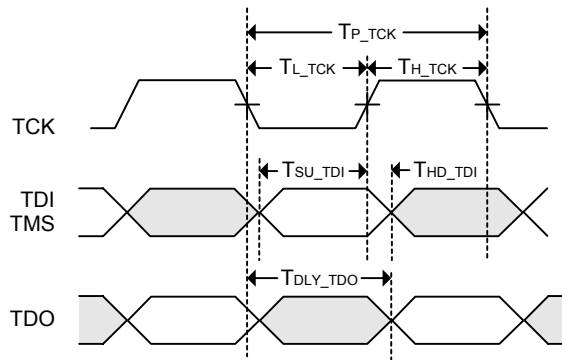

Section 5. Package Mechanical Dimensions

5.1 88E3016 Package Mechanical Dimensions

Figure 23: 88E3016 64-pin QFN package

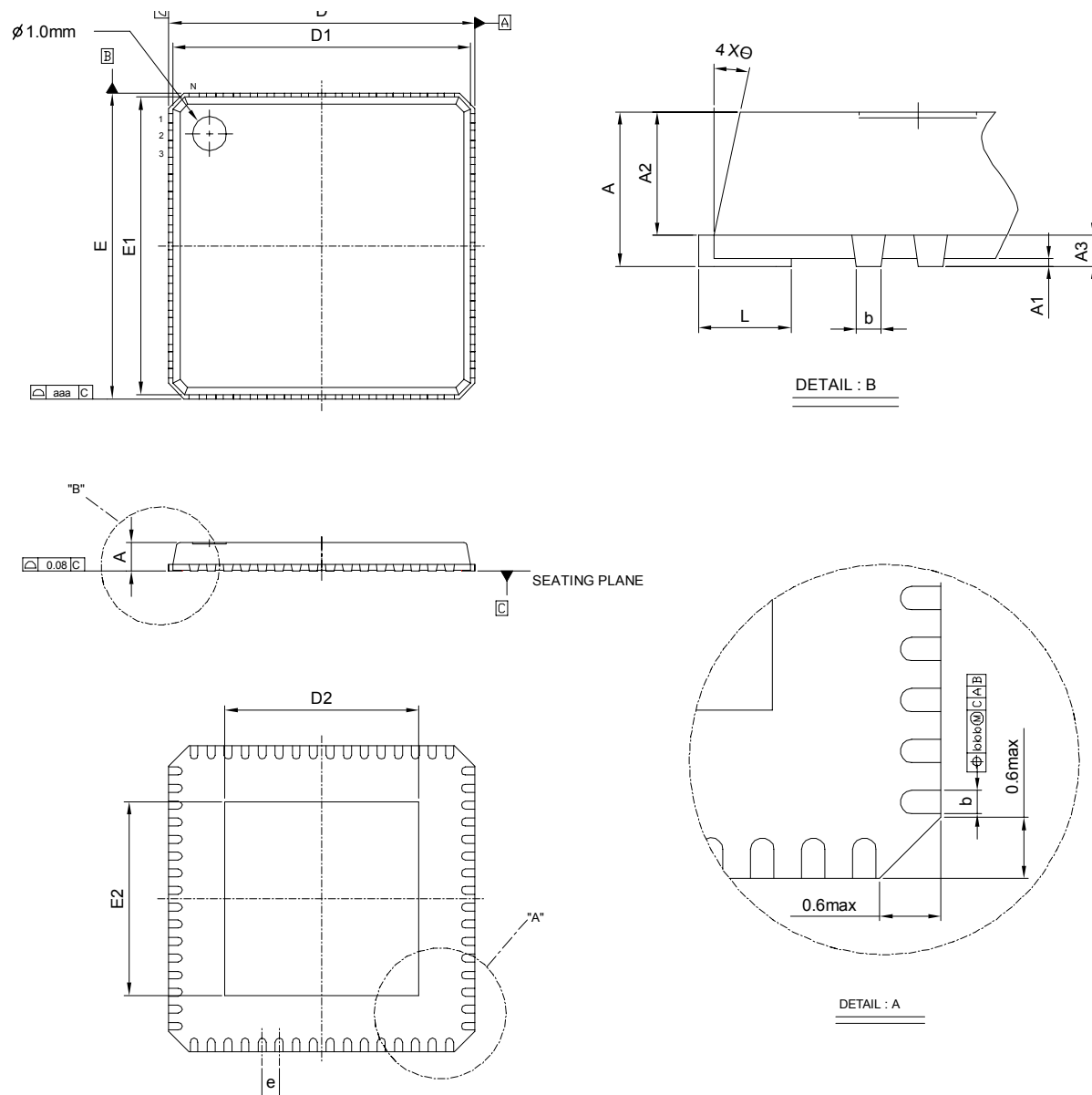

Table 58: 64-Pin QFN Mechanical Dimensions

| Symbol | Dimensions in mm | | |
|---------|------------------|------|------|
| | MIN | NOM | MAX |
| A | 0.80 | 0.85 | 1.00 |
| A1 | 0.00 | 0.02 | 0.05 |
| A2 | -- | 0.65 | 1.00 |
| A3 | 0.20 REF | | |
| b | 0.18 | 0.23 | 0.30 |
| D | 9.00 BSC | | |
| D1 | 8.75 BSC | | |
| E | 9.00 BSC | | |
| E1 | 8.75 BSC | | |
| e | 0.50 BSC | | |
| L | 0.30 | 0.40 | 0.50 |
| θ | 0° | -- | 12° |
| aaa | -- | -- | 0.25 |
| bbb | -- | -- | 0.10 |
| chamfer | -- | -- | 0.60 |

| Die Pad Size | |
|----------------|-----------------|
| Symbol | Dimension in mm |
| D ₂ | 3.78 ± 0.20 |
| E ₂ | 3.78 ± 0.20 |

Section 6. Application Examples

6.1 10BASE-T/100BASE-TX Circuit Application

Figure 24: 10BASE-T/100BASE-TX Circuit Application

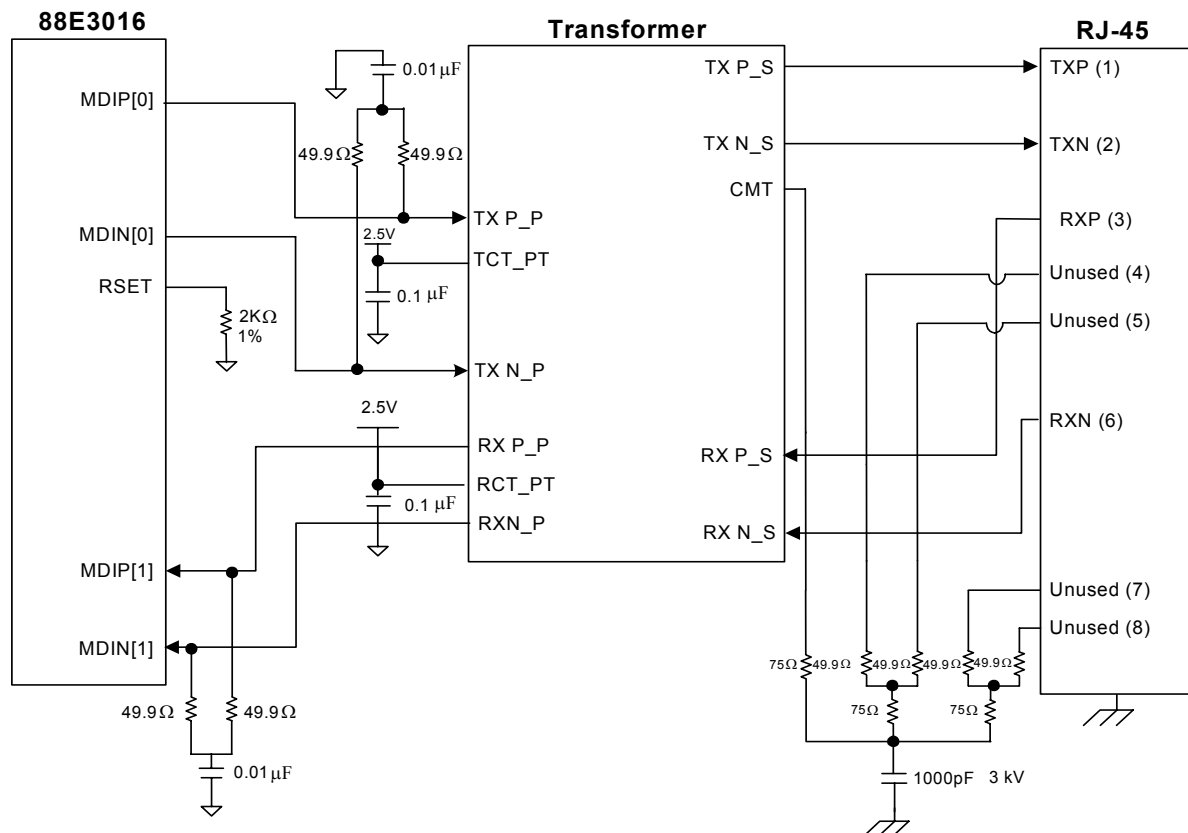

6.2 FX Interface to 3.3V Fiber Transceiver

Figure 25: FX Interface to 3.3V Fiber Transceiver

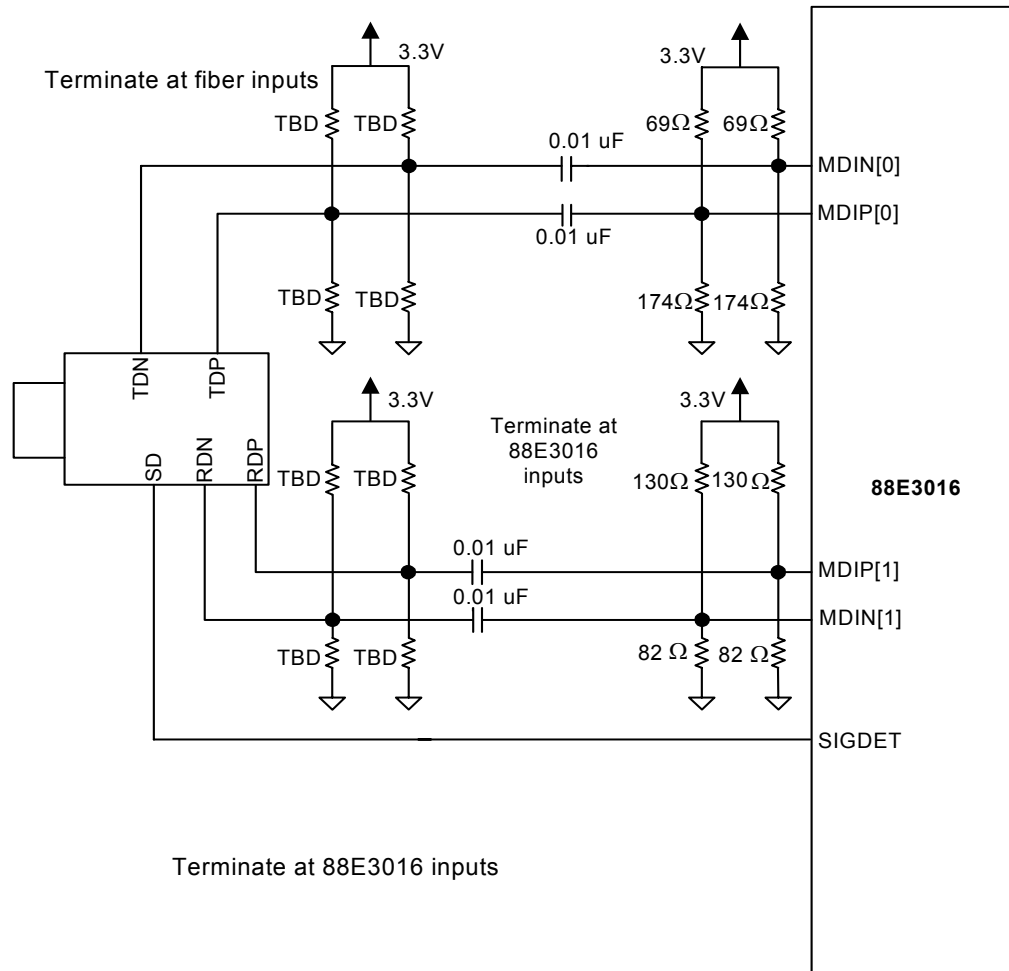

TBD -- To be determined by the application of the fiber module.

6.3 Transmitter - Receiver Diagram

Figure 26: Transmitter - Receiver Diagram

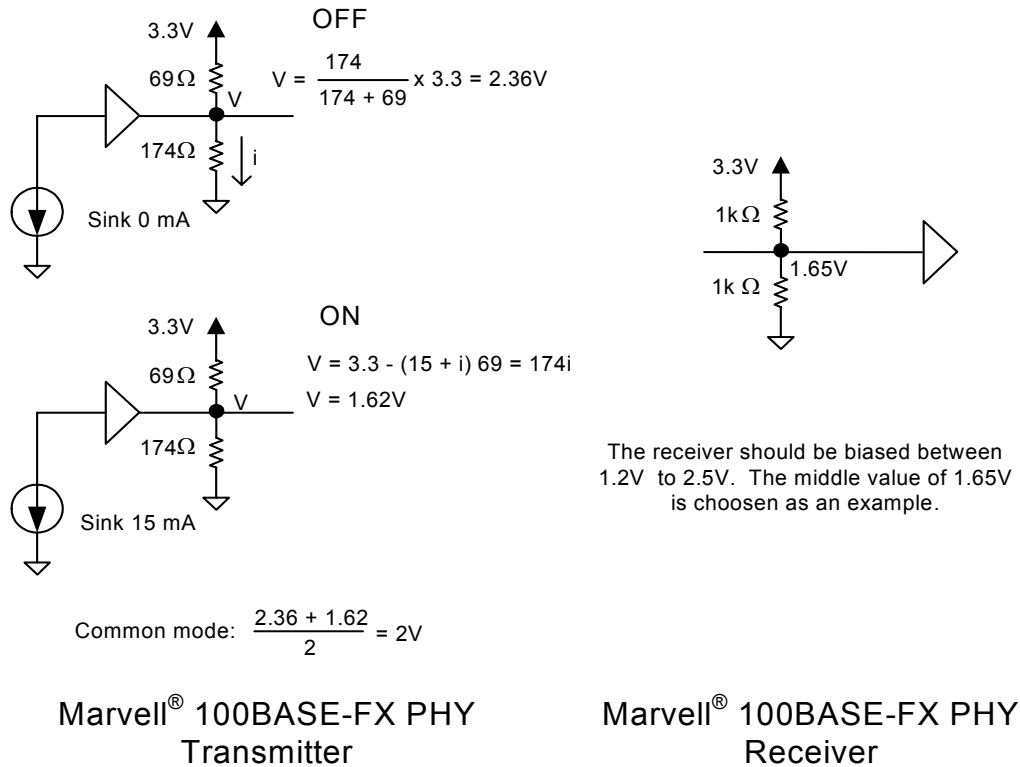

6.4 88E3016 to 88E3016 Backplane Connection - 100BASE-FX Interface

Figure 27: 88E3016 to 88E3016 Backplane Connection - 100BASE-FX Interface

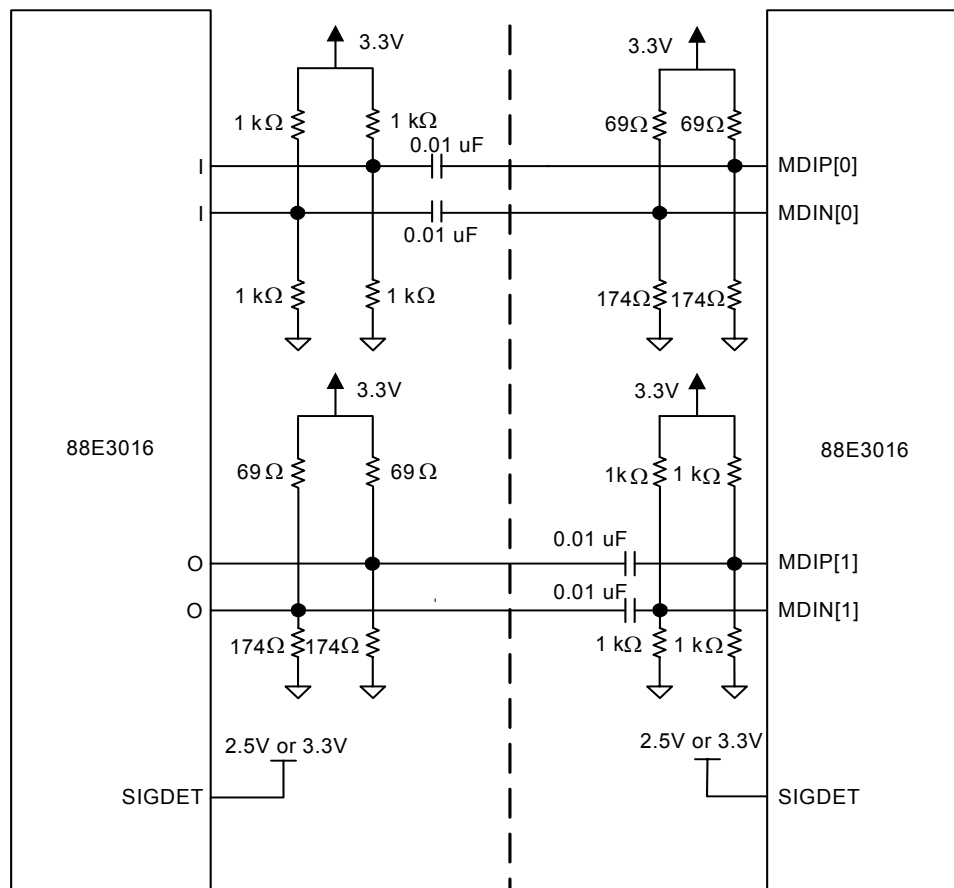

6.5 88E3016 to Another Vendor's PHY - 100BASE-FX Interface through a Backplane

Figure 28: 88E3016 to Another Vendor's PHY - 100BASE-FX Interface through a Backplane

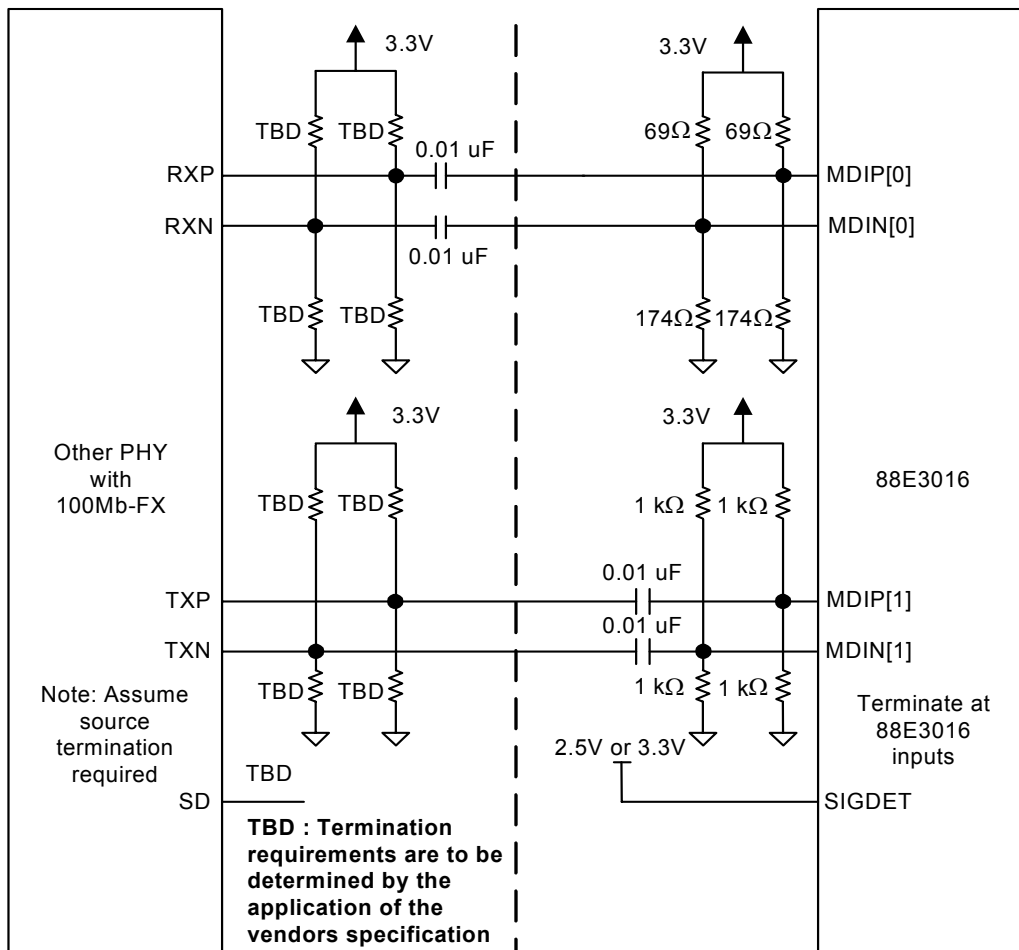

6.6 Marvell® PHY to Marvell PHY Direct Connection

Figure 29: Marvell® PHY to Marvell PHY Direct Connection

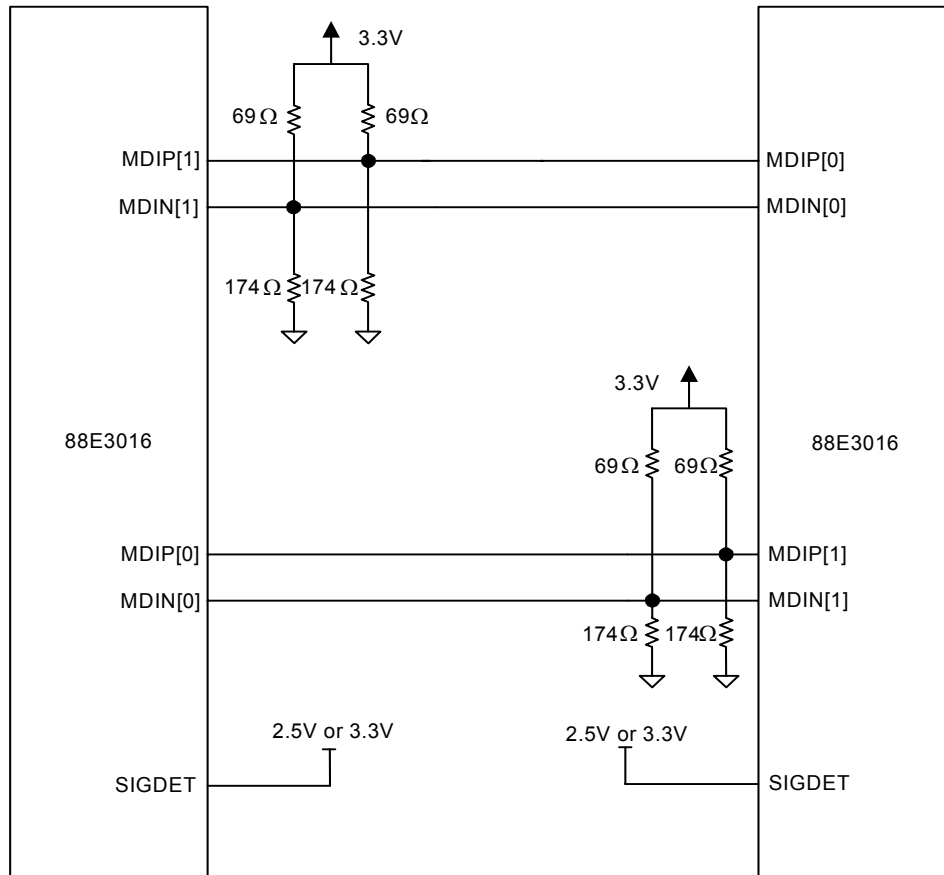

Section 7. Order Information

7.1 Ordering Part Numbers and Package Markings

Figure 30 shows the ordering part numbering scheme for the 88E3016 device. Contact Marvell® FAEs or sales representatives for complete ordering information.

Figure 30: Sample Part Number

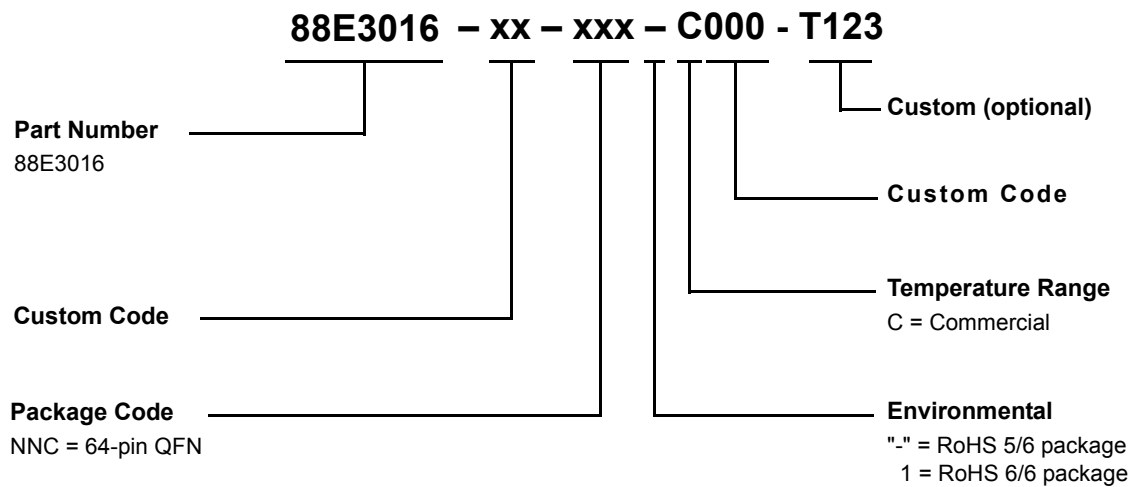

Table 59: 88E3016 Part Order Option - RoHS 5/6 Compliant Package

| Package Type | Part Order Number |
|---------------------------------|---------------------|
| 88E3016 64-pin QFN - Commercial | 88E3016-XX-NNC-C000 |

Table 60: 88E3016 Part Order Option - RoHS 6/6 Compliant Package

| Package Type | Part Order Number |
|---------------------------------|---------------------|
| 88E3016 64-pin QFN - Commercial | 88E3016-XX-NNC1C000 |

Figure 31 is an example of the package marking and pin 1 location for the 88E3016 64-pin QFN commercial RoHS 5/6 compliant package.

Figure 31: 88E3016 64-pin QFN Commercial RoHS 5/6 Compliant Package Marking and Pin 1 Location

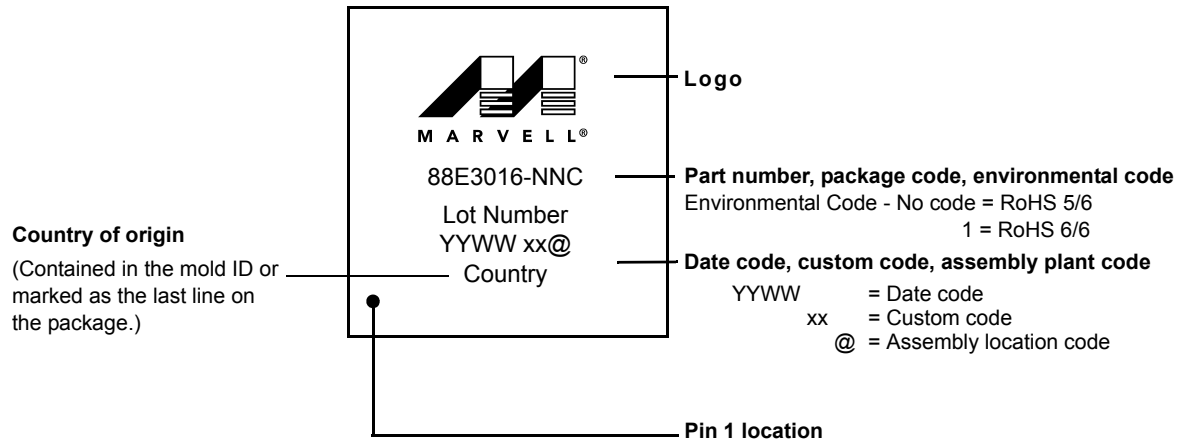

Note: The above example is not drawn to scale. Location of markings is approximate.

Figure 32 is an example of the package marking and pin 1 location for the 88E3016 64-pin QFN commercial RoHS 6/6 compliant package.

Figure 32: 88E3016 64-pin QFN Commercial RoHS 6/6 Compliant Package Marking and Pin 1 Location

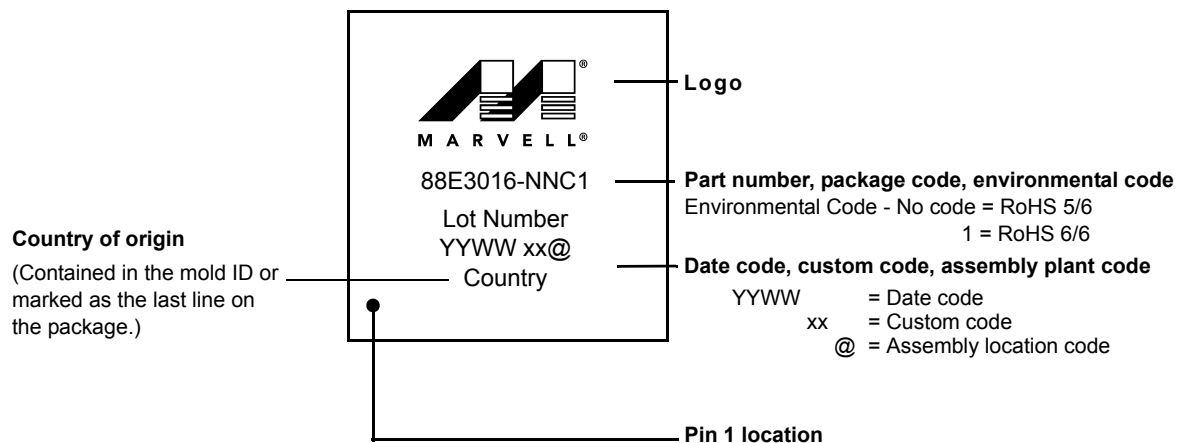

Note: The above example is not drawn to scale. Location of markings is approximate.



Marvell Semiconductor, Inc.
5488 Marvell Lane
Santa Clara, CA 95054, USA

Tel: 1.408.222.2500

Fax: 1.408.752.9028

www.marvell.com

Marvell. Moving Forward Faster