

Marvell Smart Energy Platform Solutions

Wi-Fi Microcontroller Platform



▶ OVERVIEW

Marvell®'s Wi-Fi Microcontroller Smart Energy Platform Solution provides a highly cost-effective, flexible and easy-to-use hardware/software platform to build a new generation of connected, smart devices. These smart-connected devices enable device OEMs to deliver a broad-range of services to consumers including energy-management, demand-response, home automation and remote access. This allows a user to manage comfort and convenience, also run diagnostics and receive alerts and notifications, in addition to managing and controlling the device. Developers can leverage the rich connectivity features of these new smart devices to create a new generation of innovative new applications and services.

The platform builds upon the success of Marvell's first-generation Wi-Fi microcontroller platform using the Marvell Avastar® 88W8688 Wi-Fi System-on-Chip (SoC) and Marvell Easy Connect software. Adding new enhancements and capabilities, the second-generation Smart Energy hardware platform is built with a new high-performance Marvell Cortex-M3 microcontroller (the Marvell 88MC200) optimized to run Marvell's Easy Connect software, and provides high feature integration and a broad set of I/O-interfaces. It is paired with Marvell's industry leading low-power Wi-Fi SoCs to provide best-in-class performance and rich features including IEEE 802.11n, Antenna Diversity, Beamforming, Access-Point mode and Wi-Fi Direct.

The platform is powered by production quality, field-tested Marvell Easy Connect software that includes a rich set of software components that work together to support the development of Smart Energy devices, and enable these devices to connect to mobile clients such as smart-phones, Internet-based Cloud and Smart-Grid services. The feature-rich software stack enables OEMs to focus on application-specific software functionality, thus enabling rapid development and reduced software development costs and risks.

▶ PLATFORM COMPONENTS

Marvell 88MC200 Microcontroller:

- High-performance (up to 200MHz) Cortex-M3 CPU
- 512KB SRAM
- Full-set of Serial I/O Interfaces including UART (4), SPI (3), and I2C (3)
- Up to 80 GPIOs
- High-speed connectivity interfaces for SDIO and USB-OTG (full-speed) with integrated PHY
- System peripherals including ADC, DAC, PWMs, General Purpose Timers, RTC, Watchdog
- On-Chip DC-DC Converter
- Hardware Crypto Engine
- 1MB Embedded Flash with QSPI interface to Cortex-M3
- Power management with support for low-power modes and flexible clock gating

Marvell Avastar 88W878x Wi-Fi SoCs:

- Single-chip Wi-Fi SoCs supporting 802.11 a/b/g and 802.11n standards
- WPA-2 security using AES/CCMP along with legacy security features
- Wireless Protected Setup 2.0
- Wi-Fi Direct
- Low-power modes
- Best-in-class performance and RX Sensitivity
- Antenna Diversity, Beamforming

Marvell Easy Connect Software Platform and SDK:

- Small-footprint RTOS (FreeRTOS) and Embedded TCP/IP stack (lwIP) with fully integrated drivers for 88MC200 and Marvell Avastar 88W878x SoCs
- Core system services including WLAN connection manager, persistent storage and power management.
- Networking middleware including Embedded Web Server with Web Services Framework supporting XML and JSON data exchange, HTTP Client, service discovery using mDNS/DNS-SD and security using TLS/SSL.
- A full application framework supporting easy network provisioning, service discovery and RESTful Web Services, Cloud Services Framework, firmware upgrades and greatly simplified application development.
- Advanced Wi-Fi features including 802.11n, antenna diversity, Micro-AP mode, simultaneous access-point and client mode and Wi-Fi Direct.

Marvell Smart Energy Platform Solutions

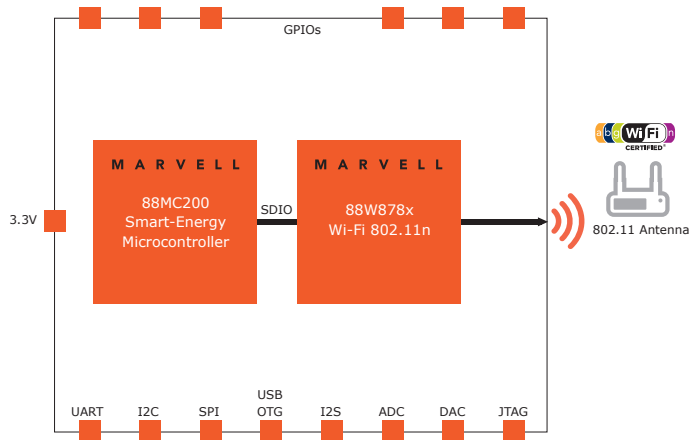

Fig 1. Marvell Smart Energy Wi-Fi Microcontroller Platform

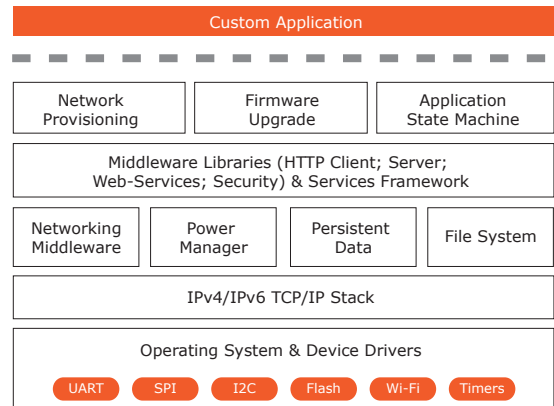

Fig 2. Marvell Easy Connect Software

COMMUNICATION AND SERVICES ARCHITECTURE

Smart-Appliances built with Marvell’s Easy Connect software are designed to seamlessly connect to a user’s home Wi-Fi network, and through that to the Internet. Devices communicate using modern web-protocols enabling developers to rapidly develop applications and services on mobile devices and cloud-servers.

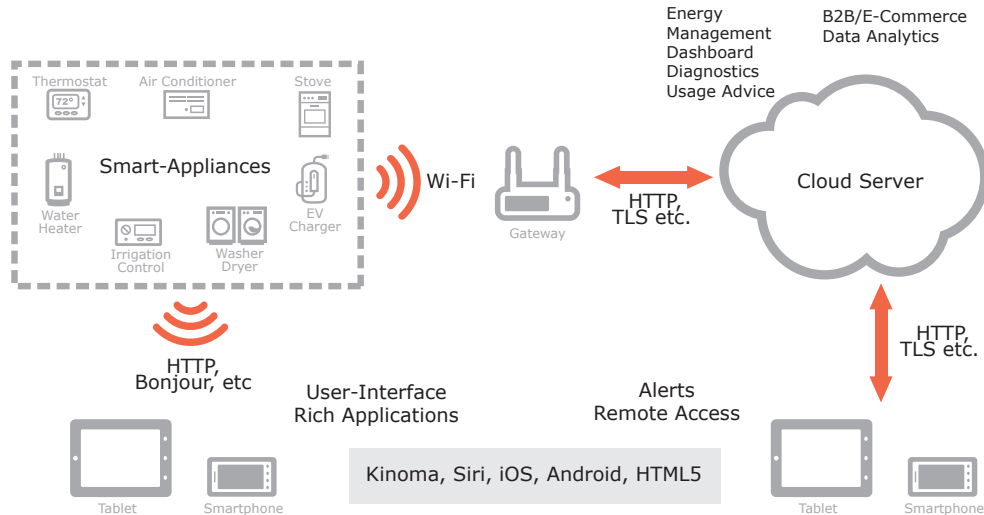

Fig 3. Communication and Services Architecture

PLATFORM FEATURES AND BENEFITS

| FEATURES | BENEFITS |
|---|--|
| <ul style="list-style-type: none"> High-performance microcontroller using advanced 55nm process with 512KB SRAM, rich set of I/O interfaces and high degrees of integration. | <ul style="list-style-type: none"> Enables offloading of entire communications and smart-energy software onto the Marvell 88MC200, with room for application software. Easily allows interfacing to commonly used peripherals such as Flash, EEPROM, LCD, push-buttons, LEDs, sensors, etc. Reduces overall system costs by reducing the number of external components in system designs, including eliminating the need for another microcontroller for device-specific functions. |

| ▶ FEATURES (Continue) | BENEFITS |
|--|--|
| <ul style="list-style-type: none"> • Marvell Avastar 88W878x low-power, full-featured SoCs supporting full 802.11 standards, including 802.11n, WPA-2 security, and advanced features such as Wi-Fi Direct, Beamforming, and more. • Simplified set-up using Wireless Protected Setup (WPS) and/or Marvell Provisioning using Marvell's Micro-AP Wi-Fi mode. | <ul style="list-style-type: none"> • Brings the full benefit of Wi-Fi, enabling seamless integration with existing Wi-Fi deployments while leveraging the latest technological developments. • Enables consumers to quickly and easily connect their devices to their home Wi-Fi network without requiring them to learn new skills or download new software. • Enables device developers to provide easy set up to consumers without adding unnecessary hardware costs to enable provisioning. |
| <ul style="list-style-type: none"> • Enables devices to provide RESTful Web Services hosted on the device; leverages the built-in standards-based software components including HTTP server, Web Services Gateway Interface, JSON and XML parsers and mDNS/DNS-SD-based Service Discovery. | <ul style="list-style-type: none"> • Enables a large ecosystem of developers to build applications on smart-phones and tablets leveraging familiar technologies available on all platforms. • Provides easy-to-use, aesthetically pleasing user-interfaces on smart-phones and tablets to manage and control devices. • Develops innovative new applications around capabilities offered by the device's sensors and controls, as well as data and information available from other sources such as Internet-based Web Services and Smart Grid. |
| <ul style="list-style-type: none"> • Smart-Energy Profile 2.0 Application Support including support for Pricing and Demand-Response/Load Control Function Sets | <ul style="list-style-type: none"> • Interfaces with Smart-Grid services such as dynamic pricing and demand-response services using the emerging Smart-Energy Profile 2.0 standard. |
| <ul style="list-style-type: none"> • Enables devices to connect to Cloud-based services, including traversal through routers with NAT and Firewalls, using industry standard protocols (http; XML; JSON; TLS) supported by Marvell Easy Connect software. | <ul style="list-style-type: none"> • Integrates the devices with Cloud-based servers to offer a broad range of services to consumers including remote access, diagnostics, alerts and notifications, and more. • Enables OEMs to develop new revenue models based on business-to-business services. |
| <ul style="list-style-type: none"> • Marvell Smart-Device Application Framework with Sample Applications | <ul style="list-style-type: none"> • Allows for the rapid development of complete device firmware to help reduce software development costs and risks. |
| <ul style="list-style-type: none"> • Micro-AP Support | <ul style="list-style-type: none"> • Allows a device to offer its own Wi-Fi access point. This allows clients, such as phones and tablets, to connect directly to the smart device without requiring a home network. |
| <ul style="list-style-type: none"> • Simultaneous Wi-Fi Client and Micro-AP Support | <ul style="list-style-type: none"> • Enables a device to connect to a home-network and offer its own network at the same time. Different services may be offered on the two network interfaces. |
| <ul style="list-style-type: none"> • Advanced Wi-Fi technologies such as Beamforming and Antenna Diversity | <ul style="list-style-type: none"> • Enhances signal reception and extends the Wi-Fi signal coverage by two to four times. |

▶ **SOFTWARE DEVELOPMENT KIT**

The software development and evaluation kit includes an 88MC200 software development board shown in Figure 3. It is paired with SD-88W878x Wi-Fi reference design to provide a complete software development kit.

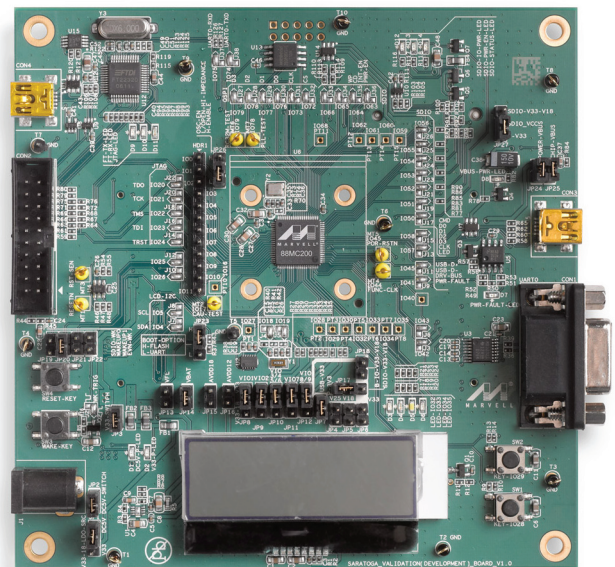
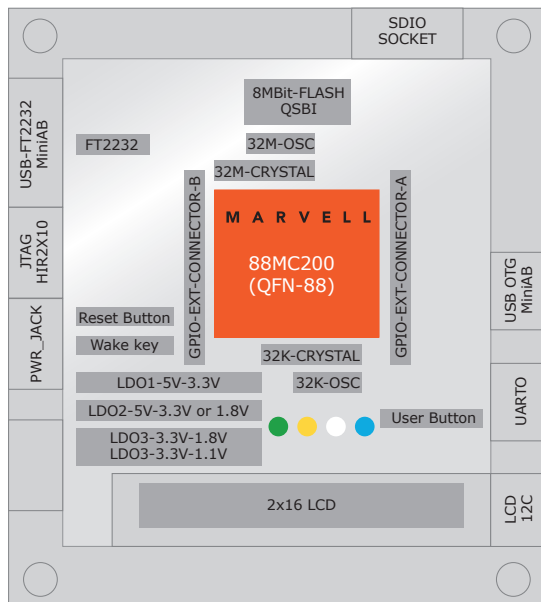

Figure 4. Marvell 88MC200 Software Development and Evaluation Kit

▶ REFERENCE MODULE

A Wi-Fi microcontroller reference module is provided with an 88MC200 and 88W8782 (2.4 GHz). It brings out all of the major 88MC200 interfaces in a compact surface mount PCB. The module provides 1 PCB antenna. It also optionally provides 2 u.FL connectors for external antennae and support for antenna diversity.

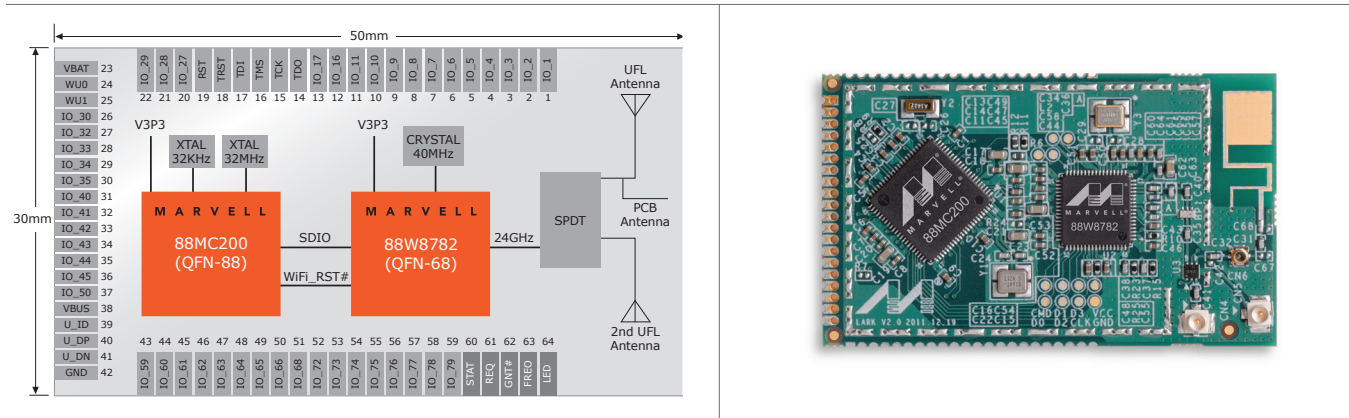

Figure 5. Marvell Smart Energy Wi-Fi Microcontroller Reference Module

▶ APPLICATIONS

The Smart Energy platform is designed to bring smart-connectivity to a broad range of devices, including:

- Thermostats
- Washer, Dryers, Dishwashers
- EV-Chargers
- Irrigation Timers
- Plug-Strips
- Air Conditioners
- Cooking Ranges
- Sensors
- Solar Inverters
- Load-Controllers
- Hot-Water Heaters
- Refrigerators
- Lighting Controls
- Smart-Outlets
- Gateways

THE MARVELL ADVANTAGE: Marvell chipsets come with complete reference designs which include board layout designs, software, manufacturing diagnostic tools, documentation, and other items to assist customers with product evaluation and production. Marvell's worldwide field application engineers collaborate closely with end customers to develop and deliver new leading-edge products for quick time-to-market. Marvell utilizes world-leading semiconductor foundry and packaging services to reliably deliver high-volume and low-cost total solutions.

ABOUT MARVELL: Marvell is a leader in storage, communications, and consumer silicon solutions. Marvell's diverse product portfolio includes switching, transceiver, communications controller, processor, wireless, power management, and storage solutions that power the entire communications infrastructure, including enterprise, metro, home, storage, and digital entertainment solutions. For more information, visit our Web site at www.marvell.com.



Marvell Semiconductor, Inc.
5488 Marvell Lane
Santa Clara, CA 95054
Phone 408.222.2500
www.marvell.com

Copyright © 2012. Marvell International Ltd. All rights reserved. Marvell, and the Marvell logo are registered trademarks of Marvell or its affiliates. All other trademarks are the property of their respective owners.