

Marvell® 88Q111x Second Generation Automotive 100BASE-T1 PHY

OPEN Alliance TC10 and IEEE 802.3bw compliant Automotive Ethernet PHY

Overview

The Marvell 88Q1110/88Q1111 device is a single pair Ethernet physical layer transceiver (PHY) designed for automotive applications. The transceiver implements the Ethernet physical layer portion of the 100BASE-T1 standard as defined by the IEEE 802.3bw task force.

The Marvell 88Q1110/88Q1111 is manufactured using a standard digital CMOS process and contains all the active circuitry required to implement the physical layer functions to transmit and receive data on a single balanced twisted pair. The 88Q1110 device supports reduced pin count GMII (RGMII), reduced pin count MII (RMII), and media independent interface (MII). The 88Q1111 device also supports Serial GMII (SGMII) for direct connection to a MAC or switch port. SGMII operates at 1.25 Gbps over a single differential pair, reducing power and number of I/Os used on the MAC interface. It integrates media dependent interface (MDI) termination resistors into the PHY. This resistor integration simplifies board layout and reduces

board cost by reducing the number of external components. It has an integrated linear voltage regulator to generate all required voltages.

The device can run off a single 3.3V supply. The device supports 1.8V, 2.5V, and 3.3V LVCMOS I/O standards. The 88Q1110/88Q1111 is designed to support frame preemption per IEEE 802.3br-2016. It uses advanced mixed-signal processing to perform equalization, echo, data recovery, and error correction at a 100 Mbps data rate.

The device achieves robust performance and exceeds automotive electromagnetic interference (EMI) requirements in noisy environments with very low-power dissipation. This device is compatible to the footprint of the Marvell 88Q1010 100BASE-T1 and 88Q2110 100/1000BASE-T1 Ethernet PHY transceivers.

Block Diagram

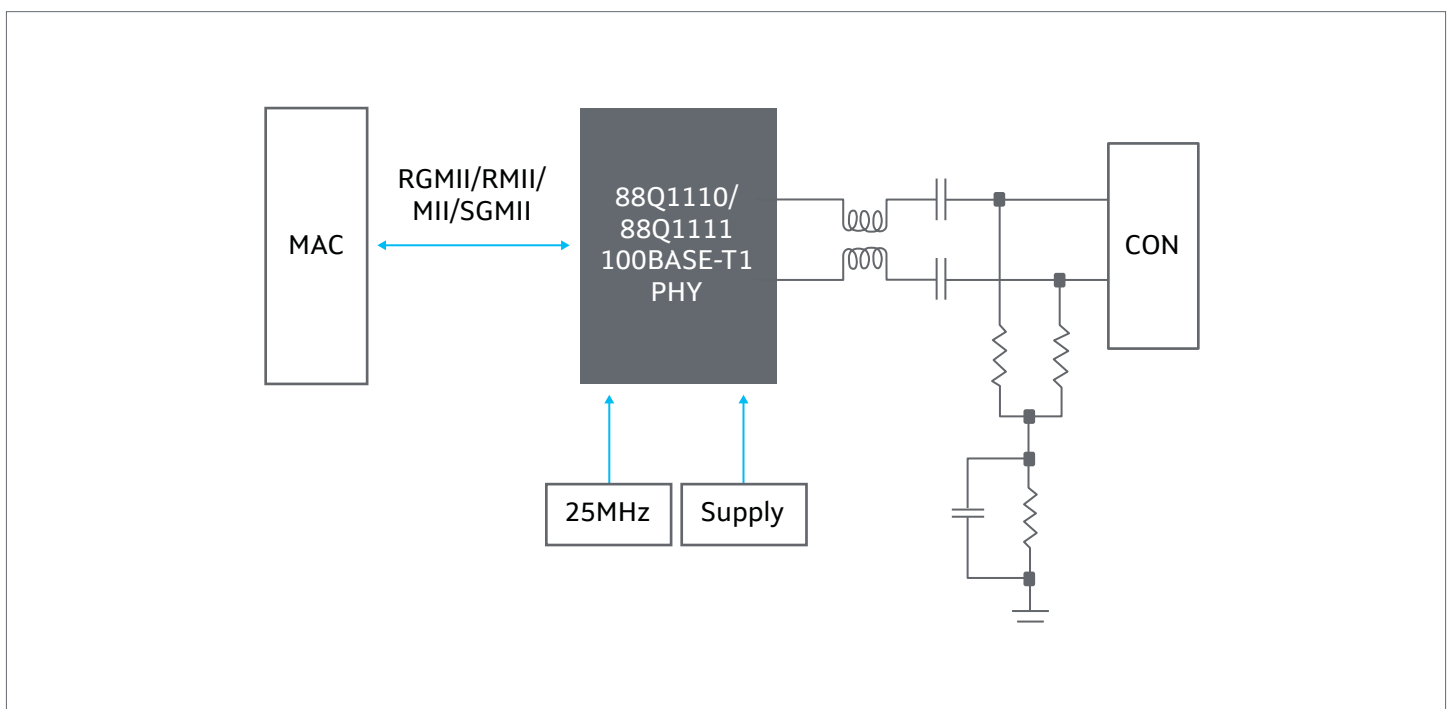

Key Features

Features	Benefits
Automotive Qualified	<ul style="list-style-type: none">• AEC-Q100• Automotive Grade 1 (-40 °C to +125 °C)
Automotive Package	<ul style="list-style-type: none">• 40-QFN, 6.0x6.0 mm, 0.5 mm pitch, wettable flanks
OPEN Alliance TC10 Sleep Mode	<ul style="list-style-type: none">• As an IEEE and OPEN Alliance TC10 compliant 100BASE-T1 Ethernet PHY, the 88Q1110/88Q1111 supports wake-up and sleep signaling over dedicated I/O pins, as well as through Wake-up Pulse (WUP), Wake-up Request (WUR) and Low Power Sleep (LPS) commands
Wake on LAN (WoL)	<ul style="list-style-type: none">• Saves system power through magic packet or link change detection
Integrated LDO	<ul style="list-style-type: none">• 3.3V only operation
Integrated passive filter network	<ul style="list-style-type: none">• Reduced BOM/board space
Integrated Virtual Cable Tester	<ul style="list-style-type: none">• VCT tool used for cable diagnostics
Signal quality indicator (SQI)	<ul style="list-style-type: none">• Signal quality indicator (SQI) tool provides signal-to-noise ratio (SNR) data
802.1AS and 1-step PTP	<ul style="list-style-type: none">• Support for Precision time protocol (PTP)

Target Applications

88Q111x is an ideal 100BASE-T1 PHY that is OPEN Alliance TC10 and IEEE 802.3bw compliant can be deployed in various domains the car, including:

- Automotive infotainment systems
- Advanced driver assist systems
- Telematic control units
- Instrumentation clusters



Marvell first revolutionized the digital storage industry by moving information at speeds never thought possible. Today, that same breakthrough innovation remains at the heart of the company's storage, networking and connectivity solutions. With leading intellectual property and deep system-level knowledge, Marvell semiconductor solutions continue to transform the enterprise, cloud, automotive, industrial, and consumer markets. For more information, visit www.marvell.com.

© 2020 Marvell. All rights reserved. The MARVELL mark and M logo are registered and/or common law trademarks of Marvell and/or its Affiliates in the US and/or other countries. This document may also contain other registered or common law trademarks of Marvell and/or its Affiliates.