

Marvell® Brightlane™ 88Q120xM MACsec integrated Automotive 100Base-T1 PHY

Integrated MACsec, Open Alliance TC10 and IEEE 802.3bw compliant Automotive Ethernet PHY

Overview

The Marvell Brightlane™ 88Q1200M/88Q1201M device is a single-pair Ethernet physical layer transceiver (PHY) that supports operation over unshielded twisted pair (UTP). The transceiver implements the Ethernet physical layer portion of 100BASE-T1 as defined by the IEEE 802.3bw standard.

The 88Q120xM has integrated MACsec that secures against the Layer 2 In-Vehicle Networking security threats. MACsec secures data exchange on a hop-by-hop basis and prevents attacks such as intrusion, man-in-the-middle, and replay attacks.

The 88Q120xM is manufactured using a standard digital CMOS process and contains all the active circuitry required to implement the physical layer functions to transmit and receive data on a single balanced twisted pair. The device family supports reduced pin count GMII (RGMII) and SGMII for direct connection to a MAC/switch port.

The device integrates media dependent interface (MDI) termination resistors into the PHY. This resistor integration simplifies board layout and reduces board cost by reducing the number of external components. The device has a voltage regulator to generate all required voltages. The device can run off a single 3.3V supply. The device supports 1.8V, 2.5V, and 3.3V LVCMOS I/O standards.

The device uses advanced mixed-signal processing to perform equalization, echo and crosstalk cancellation, data recovery, and error correction at a data rate of 100 Mbps. The device achieves robust performance and exceeds electromagnetic interference (EMI) requirements in noisy environments with very low power dissipation.

Block Diagram

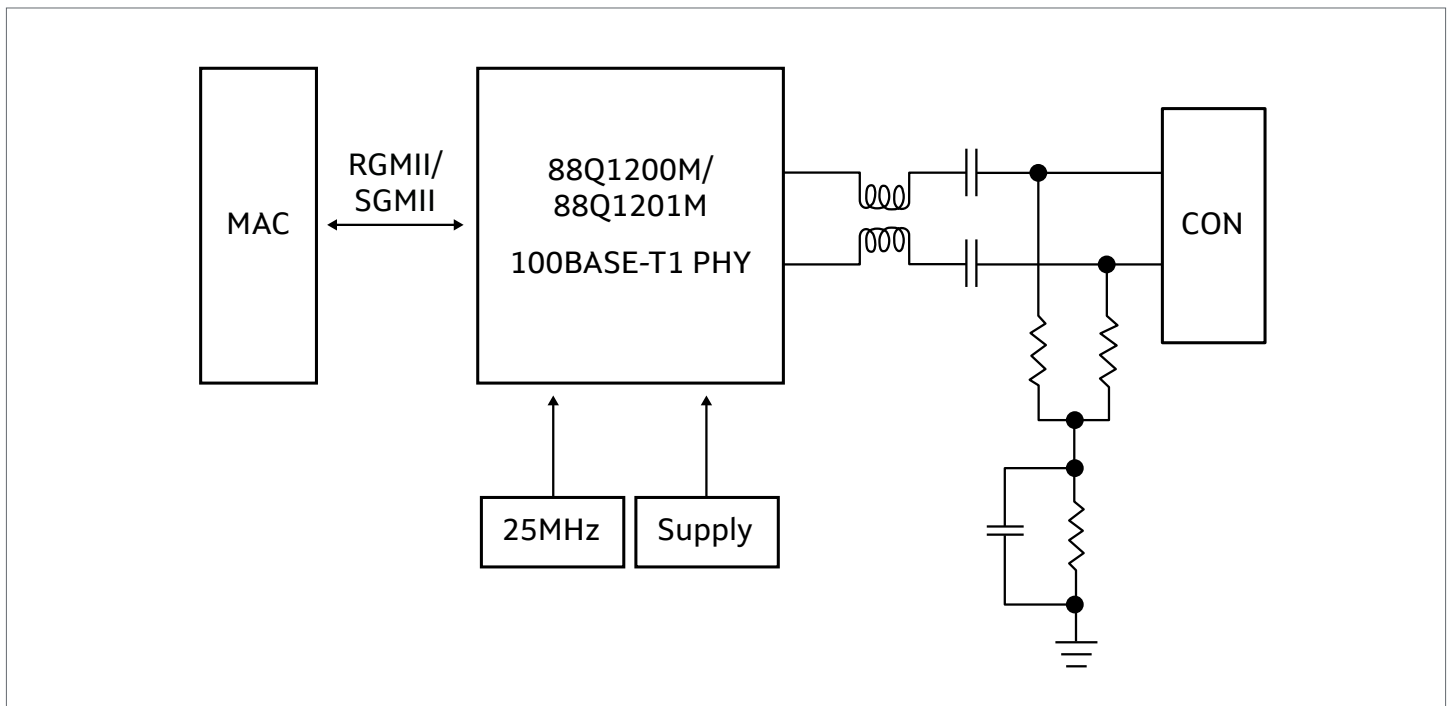

Marvell Brightlane™ 88Q120xM Block Diagram

Key Features

Features	Benefits
100BASE-T1, IEEE 802.3bw-compliant	<ul style="list-style-type: none">Automotive Ethernet PHY supports operation over unshielded twisted pair (UTP)
Supports IEEE 802.1AE MACsec	<ul style="list-style-type: none">MACsec provides Layer 2 security
OPEN Alliance TC10 Sleep Mode	<ul style="list-style-type: none">As an IEEE and OPEN Alliance TC10 compliant 100BASE-T1 Ethernet PHY, the device supports wake-up and sleep signaling over dedicated I/O pins, as well as through Wake-up Pulse (WUP), Wake-up Request (WUR) and Low Power Sleep (LPS) commands
Automotive Qualified	<ul style="list-style-type: none">AEC-Q100Automotive Grade 1 (-40 °C to +125 °C)
Automotive Package	<ul style="list-style-type: none">40-QFN, 6.0x6.0 mm, 0.5 mm pitch, wettable flanks
Wake on LAN (WoL)	<ul style="list-style-type: none">Saves system power through magic packet or link change detection
Integrated Voltage Regulators	<ul style="list-style-type: none">3.3V only operation
Integrated passive filter network	<ul style="list-style-type: none">Reduced BOM/board space
Integrated Virtual Cable Tester	<ul style="list-style-type: none">VCT tool used for cable diagnostics
Signal quality indicator (SQI)	<ul style="list-style-type: none">Signal quality indicator (SQI) tool provides signal-to-noise ratio (SNR) data
802.1AS and 1-step PTP	<ul style="list-style-type: none">Support for Precision time protocol (PTP)

Target Applications

88Q120xM is a secure 100BASE-T1 PHY that has an integrated MACsec and is OPEN Alliance TC10 and 802.3bw compliant, which can be deployed in various domains in the car, including:

- Automotive infotainment systems
- Advanced driver assist systems
- Telematic control units
- Instrumentation clusters



To deliver the data infrastructure technology that connects the world, we're building solutions on the most powerful foundation: our partnerships with our customers. Trusted by the world's leading technology companies for 25 years, we move, store, process and secure the world's data with semiconductor solutions designed for our customers' current needs and future ambitions. Through a process of deep collaboration and transparency, we're ultimately changing the way tomorrow's enterprise, cloud, automotive, and carrier architectures transform—for the better.

Copyright © 2021 Marvell. All rights reserved. Marvell and the Marvell logo are trademarks of Marvell or its affiliates. Please visit www.marvell.com for a complete list of Marvell trademarks. Other names and brands may be claimed as the property of others.