

Marvell® Brightlane™ 88QB5224 Automotive Ethernet bridge for in-vehicle video distribution

IEEE 802.3ch compliant, MIPI CSI-2 interface, Multi camera support & I2C Support

Overview

The Marvell Brightlane™ 88QB5224 device is an Automotive Ethernet Bridge device that bridges 4 lanes of MIPI CSI-2 with an automotive ethernet multigig PHY. 88QB5224 supports operation over shielded twisted pair (STP) and implements the Ethernet physical layer portion of 10GBASE-T1 as defined by the IEEE 802.3ch standard.

The 88QB5224 is designed to directly connect to automotive-grade Cameras, Graphics Processing Units (GPUs), etc., via CSI-2 interface as defined by the MIPI Alliance. Device can transfer video data from multiple co-located cameras over the 10GBASE-T1 interface.

The 88QB5224 supports I2C interface for local and remote control of the camera sensor module.

The 88QB5224 is manufactured using a standard digital CMOS process and contains all the active circuitry required to implement the physical layer functions to transmit and receive data on a single balanced twisted pair.

The device uses advanced mixed-signal processing to perform equalization, echo cancellation, data recovery, and error correction at full line rate. The device achieves robust performance and exceeds automotive electromagnetic interference (EMI) requirements in noisy environments with very low power dissipation.

Block Diagram

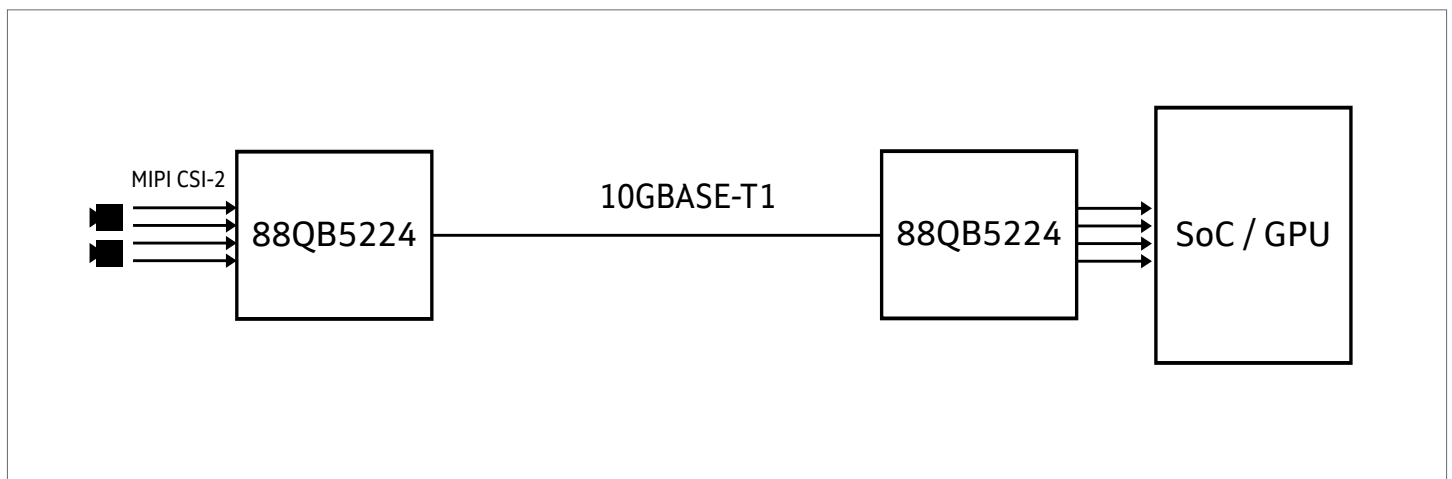

Marvell Brightlane™ 88QB5224 Block Diagram

Key Features

Features	Benefits
10GBASE-T1, IEEE 802.3ch compliant PHY	<ul style="list-style-type: none">Automotive Ethernet PHY supports operation over shielded twisted pair (STP)
4 lanes of MIPI CSI-2	<ul style="list-style-type: none">4 lanes of MIPI CSI-2 DPHY with capability to interface 1 to 4 camera sensors
I2C Interface	<ul style="list-style-type: none">Capability for local and remote I2C Control of sensors
Automotive Qualified	<ul style="list-style-type: none">AEC-Q100Automotive Grade 2 (-40 °C to +105 °C)

Target Applications

88QB5224 is an automotive ethernet bridge for in-vehicle video distribution. Video distribution over ethernet enables in-vehicle video distribution over the established ethernet network and thus providing multiple benefits associated with ethernet. 88B5224 is ideal for ECUs such as:

- Automotive infotainment systems
- Advanced driver assist systems
- Autonomous Drive Systems



To deliver the data infrastructure technology that connects the world, we're building solutions on the most powerful foundation: our partnerships with our customers. Trusted by the world's leading technology companies for 25 years, we move, store, process and secure the world's data with semiconductor solutions designed for our customers' current needs and future ambitions. Through a process of deep collaboration and transparency, we're ultimately changing the way tomorrow's enterprise, cloud, automotive, and carrier architectures transform—for the better.

Copyright © 2021 Marvell. All rights reserved. Marvell and the Marvell logo are trademarks of Marvell or its affiliates. Please visit www.marvell.com for a complete list of Marvell trademarks. Other names and brands may be claimed as the property of others.