



88SE9235 R1.1

Two-Lane PCIe 2.0 to Four-Port 6
Gbps SATA I/O Controller

Datasheet

Doc No. MV-S108467-U0 Rev. D

December 5, 2018

Document Classification: Public



For more information, visit our website at: www.marvell.com

This Document And The Information Furnished In This Document Are Provided "As Is" Without Any Warranty. Marvell Expressly Disclaims And Makes No Warranties Or Guarantees, Whether Express, Oral, Implied, Statutory, Arising By Operation Of Law, Or As A Result Of Usage Of Trade, Course Of Dealing, Or Course Of Performance, Including The Implied Warranties Of Merchantability And Fitness For Particular Purpose And Non-infringement.

This document, including any software or firmware included or referenced in this document is owned by Marvell. The information furnished in this document is provided for reference purposes only for use with Marvell products. It is the user's own responsibility to design or build products with the information. Marvell products are not authorized for use as critical components in medical devices, military systems, life or critical support devices, or related systems. Marvell is not liable, in whole or in part, and the user shall indemnify and hold Marvell harmless for any claim, damage, or other liability related to any such use of Marvell products. Marvell and the Marvell logo are registered trademarks of Marvell. For a more complete listing of Marvell trademarks, visit www.marvell.com.

Copyright © 2018. Marvell International Ltd. All rights reserved.

ORDERING INFORMATION

Ordering Part Numbers and Package Markings

The following figure shows the ordering part numbering scheme for the 88SE9235 part. For complete ordering information, contact your Marvell FAE or sales representative.

Sample Ordering Part Number

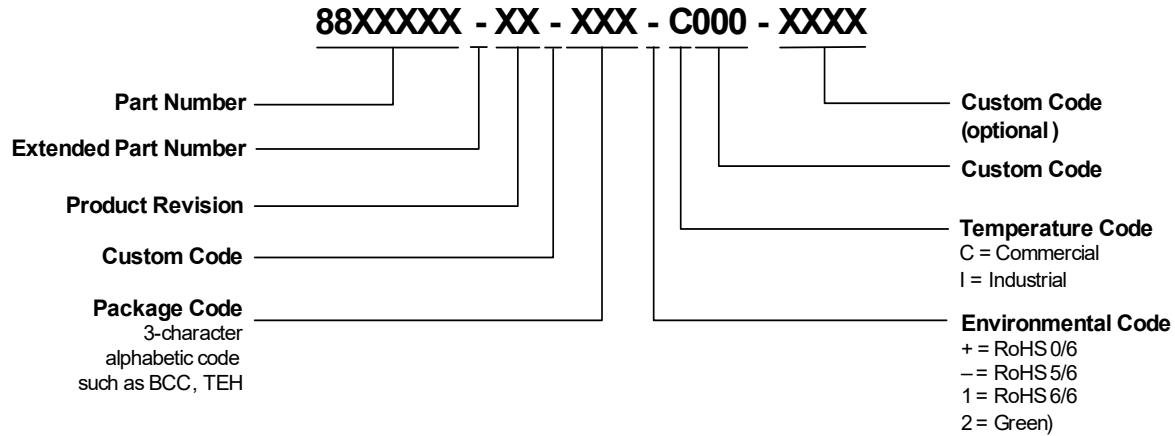

The standard ordering part numbers for the respective solutions are indicated in the following table.

Ordering Part Numbers

Part Number	Description
88SE9235A1-NAA2C000	76-pin QFN 9 mm × 9 mm, Two-Lane PCIe 2.0 to four-port 6 Gbps SATA Controller.
88SE9235A1-NAA2I000	76-pin Industrial Grade QFN 9 mm × 9 mm, Two-Lane PCIe 2.0 to four-port 6 Gbps SATA Controller.

The next figure shows a typical Marvell package marking.

88SE9235 Package Marking and Pin 1 Location

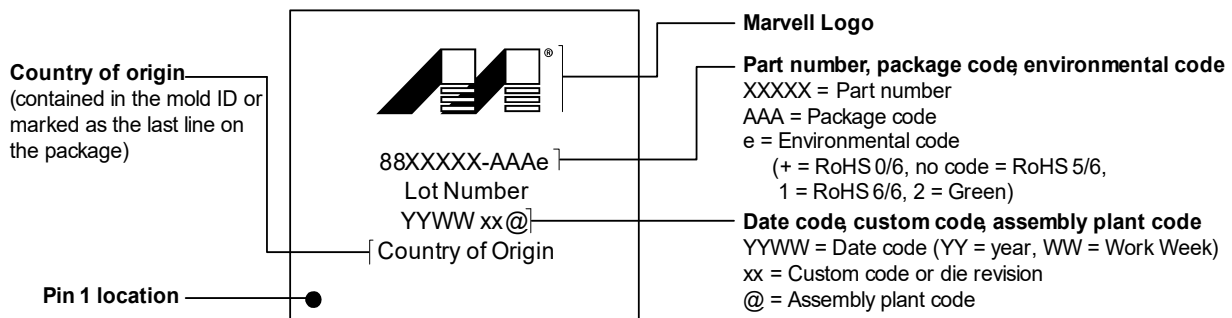

Note: The above drawing is not drawn to scale. The location of markings is approximate. Add-on marks are not represented. Flip chips vary widely in their markings and flip chip examples are not shown here. For flip chips, the markings may be omitted per customer requirement.



THIS PAGE LEFT INTENTIONALLY BLANK

CHANGE HISTORY

The following table identifies the document change history for Rev. D.

Document Changes *

Location	Type	Description	Date
Global	Update	Removed "Confidential" from footer and watermark.	December 13, 2016
Global	Update	Removed "preliminary" designation from titles and page headers.	April 4, 2018
Page 4-1	Update	Updated the following in Chapter 4, Layout Guidelines : The information in this chapter is preliminary. Please consult with Marvell Semiconductor design and application engineers before starting your PCB design. to Note: <i>The information in this chapter is intended only to provide guidelines, and is not meant to restrict the customer from exercising discretion in implementing board designs. In cases where it is deemed necessary to deviate from the guidelines, Marvell recommends that customers consult with the Marvell FAEs to ensure that the performance of the Marvell product is not compromised.</i>	April 6, 2018
Page 7-3	Update	Corrected Temperature settings in 7.2, Recommended Operating Conditions .	November 15, 2018

* The type of change is categorized as: Parameter, Revision, or Update. A Parameter change is a change to a spec value, a Revision change is one that originates from the chip Revision Notice, and an Update change includes all other document updates.



THIS PAGE LEFT INTENTIONALLY BLANK

CONTENTS

1	OVERVIEW	1-1
2	FEATURES	2-1
2.1	GENERAL	2-2
2.2	PCIe	2-3
2.3	SATA CONTROLLER	2-4
2.4	SPI INTERFACE CONTROLLER	2-5
2.5	PERIPHERAL INTERFACE CONTROLLER	2-6
3	PACKAGE	3-1
3.1	PIN DIAGRAM	3-2
3.2	MECHANICAL DIMENSIONS	3-3
3.3	SIGNAL DESCRIPTIONS	3-5
3.3.1	Signal Descriptions Overview	3-5
3.3.2	Pin Type Definitions	3-5
3.3.3	Signal Descriptions	3-6
4	LAYOUT GUIDELINES	4-1
4.1	LAYOUT GUIDELINES OVERVIEW	4-2
4.2	BOARD SCHEMATIC EXAMPLE	4-3
4.3	LAYER STACK-UP	4-5
4.3.1	Layer Stack-Up Overview	4-5
4.3.2	Layer 1–Topside, Parts, Slow and High Speed Signal Routes, and Power Routes	4-5
4.3.3	Layer 2–Solid Ground Plane	4-5
4.3.4	Layer 3–Power Plane	4-5
4.3.5	Layer 4–Bottom Layer, Slow and High-Speed Signal Routes, and Power Routes	4-5
4.4	POWER SUPPLY	4-6
4.4.1	Power Supply Overview	4-6
4.4.2	VDD Power (1.0V)	4-6
4.4.3	Analog Power Supply (1.8V)	4-6
4.4.4	Bias Current Resistor (RSET)	4-7
4.5	PCB TRACE ROUTING	4-8
4.6	RECOMMENDED LAYOUT	4-9
5	ELECTRICAL SPECIFICATIONS	5-1
5.1	ABSOLUTE MAXIMUM RATINGS	5-2
5.2	RECOMMENDED OPERATING CONDITIONS	5-3
5.3	POWER REQUIREMENTS	5-4
5.4	DC ELECTRICAL CHARACTERISTICS	5-5
5.5	THERMAL DATA	5-6



THIS PAGE LEFT INTENTIONALLY BLANK

1 OVERVIEW

The 88SE9235 is a four-port, 3 Gbps or 6 Gbps SATA Host Bus Adapter that provides a two-lane PCIe 2.0 interface and SATA controller functions. The 88SE9235 supplies four 6 Gbps SATA ports.

The 88SE9235 supports devices compliant with the Serial ATA International Organization: Serial ATA Revision 3.1 specification. Figure 1-1 shows the system block diagram.

Figure 1-1 88SE9235 Architecture (All Others)

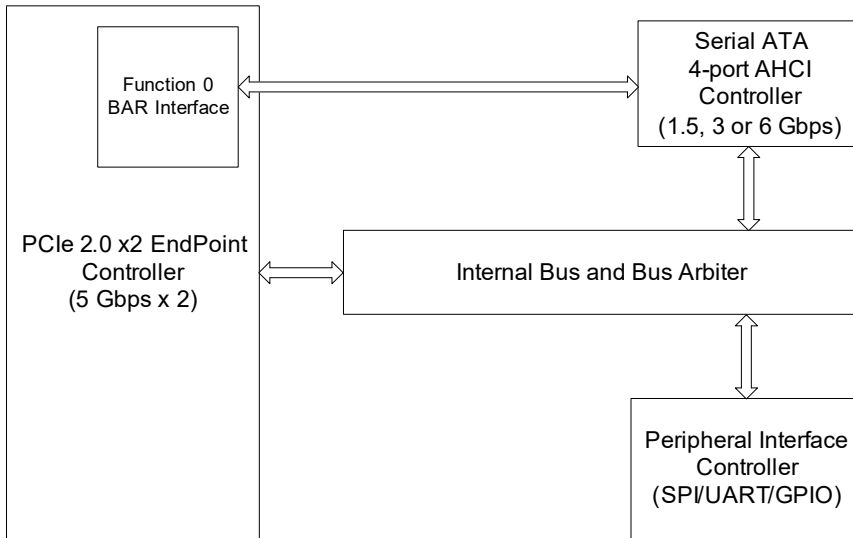



THIS PAGE LEFT INTENTIONALLY BLANK

2 FEATURES

This chapter contains the following information:

- General
- PCIe
- SATA Controller
- SPI Interface Controller
- Peripheral Interface Controller



2.1 General

- 55 nm CMOS process, 1.0V digital core, 1.8V analog, and 3.3V I/O power supplies.
- Reference clock frequency of 25 MHz, provided by an external clock source or generated by an external crystal oscillator.

2.2 PCIe

- PCIe 2.0 endpoint device.
- Compliant with PCIe 2.0 specifications.
- Supports communication speed of 2.5 Gbps and 5 Gbps.
- Supports AHCI programming interface registers for the SATA controller.
- Supports aggressive power management.
- Supports error reporting, recovery and correction.
- Supports Message Signaled Interrupt (MSI).
- Improved PCIe read request efficiency

2.3 SATA Controller

- Compliant with Serial ATA Specification 3.1.
- Supports communication speeds of 6 Gbps, 3 Gbps, and 1.5 Gbps.
- Supports programmable transmitter signal levels.
- Supports Gen 1i, Gen 1x, Gen 2i, Gen 2m, Gen 2x, and Gen 3i.
- Supports four SATA ports.
- Supports AHCI 1.0 programming interface.
- Supports Native Command Queuing (NCQ).
- Supports Port Multiplier FIS based switching or command based switching.
- Supports Partial and Slumber Power Management states.
- Supports Staggered Spin-up.

2.4 SPI Interface Controller

- A four-pin interface provides read and write access to an external SPI flash or SPI ROM device.
- Vendor specific information stored in the external device is read by the controller during the chip power-up.
- PCI BootROMs of PCIe function 0 can also be stored in the external SPI device and read through the Expansion ROM BAR and the SPI interface controller.



2.5 Peripheral Interface Controller

- Eight General Purpose I/O (GPIO) ports.
- Each of the GPIO pins can be assigned to act as a general input or output pin.
- Each of the GPIO inputs can be programmed to generate an edge-sensitive or a level-sensitive maskable interrupt.
- Each of the GPIO outputs can be programmed for a connected LED to blink at a user-defined fixed rate. The default rate is 100 ms.

3 PACKAGE

This chapter contains the following information:

- Pin Diagram
- Mechanical Dimensions
- Signal Descriptions

3.1 Pin Diagram

The 76-pin QFN pin diagram is illustrated in Figure 3-1.

Figure 3-1 SE9235 Pin Diagram

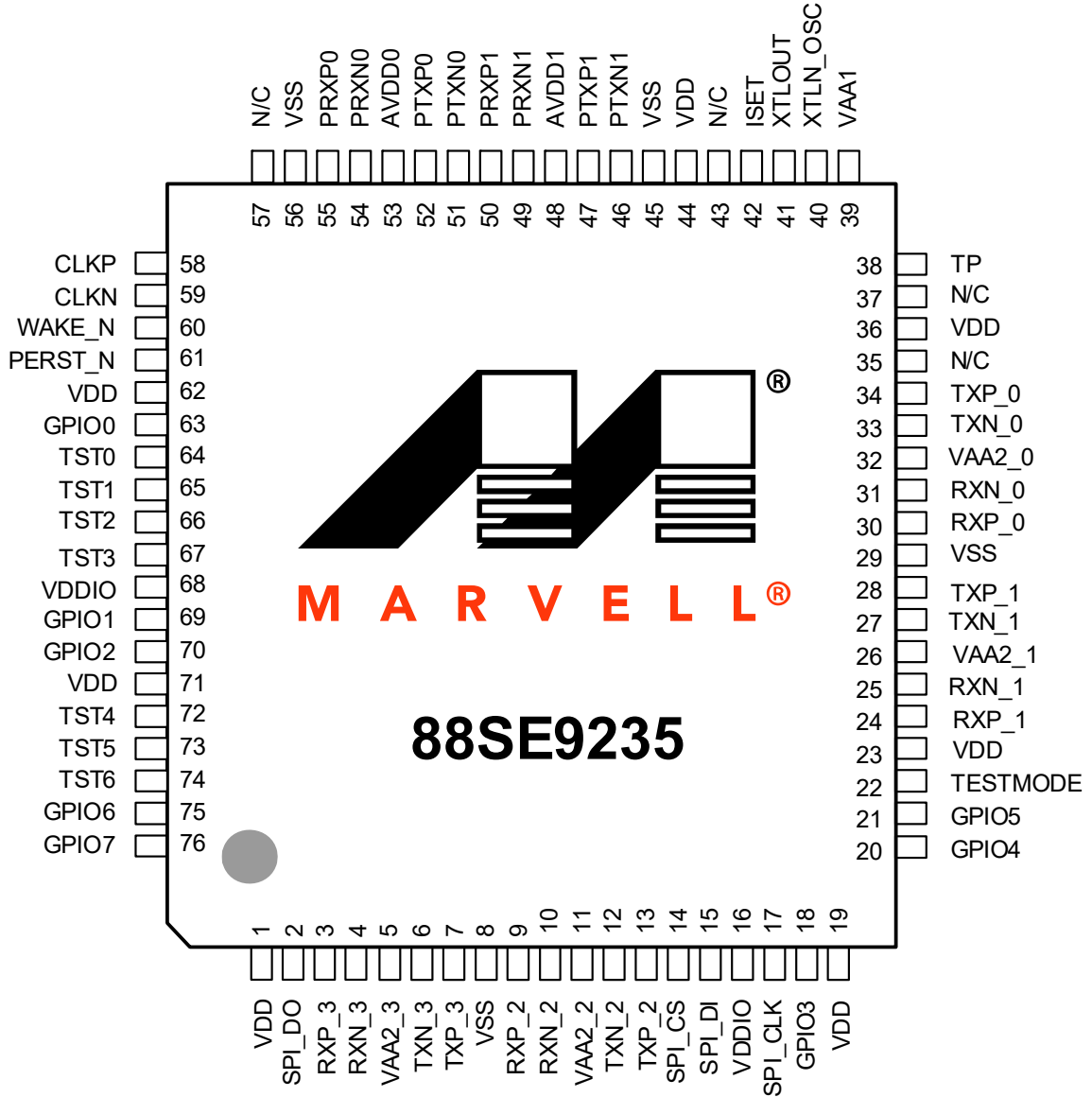

Note: The center area beneath the chip is the Exposed Die Pad (Epad). When designing the PCB, create a solder pad for the Epad and connect the Epad to ground.

3.2 Mechanical Dimensions

The package mechanical drawing is shown in Figure 3-2.

Figure 3-2 Package Mechanical Diagram

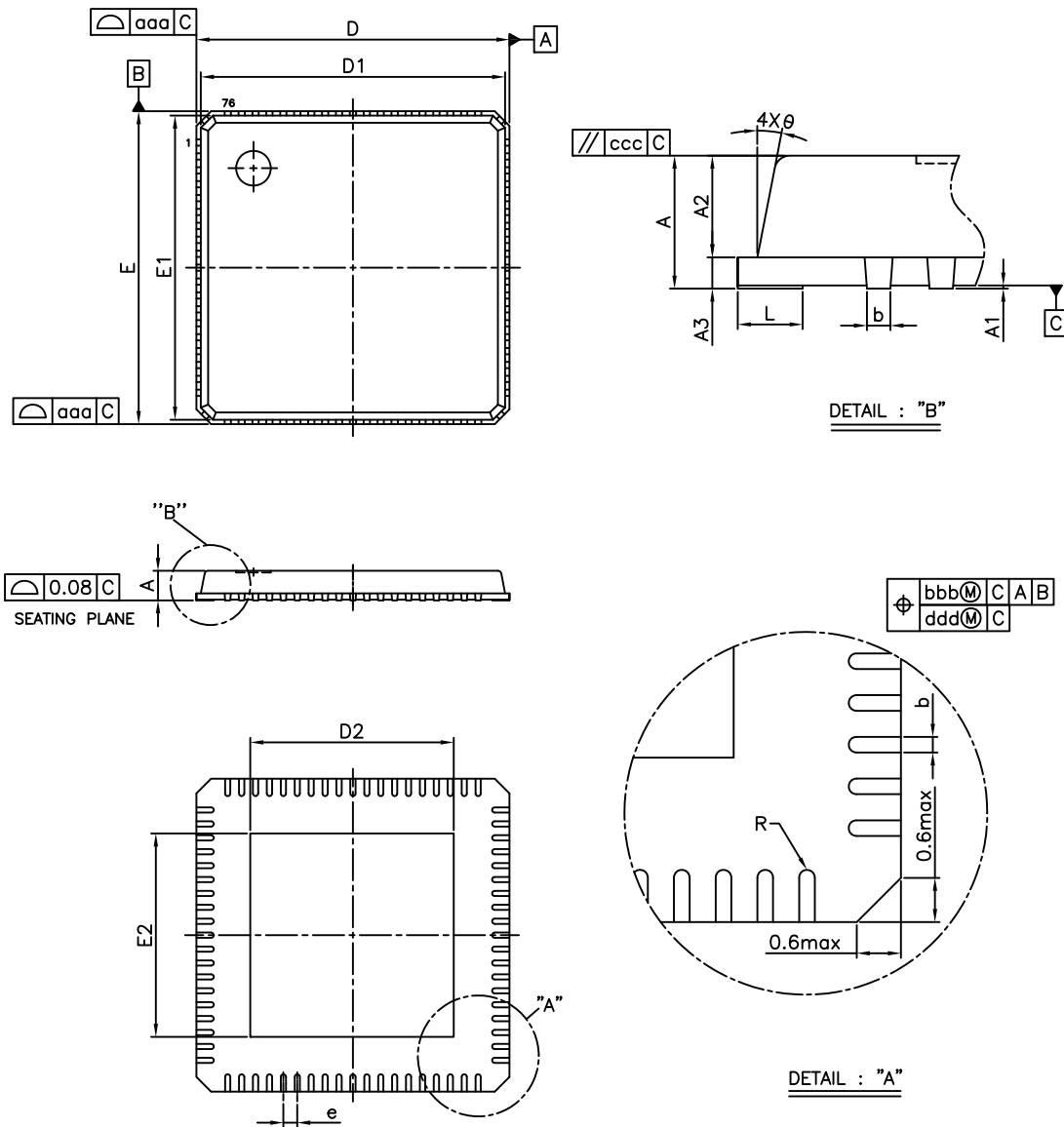

The package mechanical dimensions are shown in Figure .

Figure 3-3 Package Mechanical Dimensions

Symbol	Dimension in mm			Dimension in inch		
	MIN	NOM	MAX	MIN	NOM	MAX
A	0.80	0.85	1.00	0.031	0.033	0.039
A1	0.00	0.02	0.05	0.000	0.001	0.002
A2	---	0.65	1.00	---	0.026	0.039
A3	0.20 REF			0.008 REF		
b	0.15	0.20	0.25	0.006	0.008	0.010
D	9.00 BSC			0.354 BSC		
D1	8.75 BSC			0.344 BSC		
E	9.00 BSC			0.354 BSC		
E1	8.75 BSC			0.344 BSC		
e	0.40 BSC			0.016 BSC		
θ	0°	---	14°	0°	---	14°
R	0.075	---	---	0.003	---	---
aaa	---	---	0.15	---	---	0.006
bbb	---	---	0.10	---	---	0.004
ccc	---	---	0.10	---	---	0.004
ddd	---	---	0.05	---	---	0.002
chamfer	---	---	0.60	---	---	0.024

Exposed Die Pad Size / Lead length Options			
Option	Symbol	Dimension in mm	Dimension in inch
#3	D2	4.90 ± 0.20	0.193 ± 0.008
	E2	4.90 ± 0.20	0.193 ± 0.008
	L	0.40 ± 0.10	0.016 ± 0.004

NOTE:

1. CONTROLLING DIMENSION : MILLIMETER
2. REFERENCE DOCUMENT: PROPSD JEDEC MO-220.

3.3 Signal Descriptions

This section contains the following information:

- [Signal Descriptions Overview](#)
- [Pin Type Definitions](#)
- [Signal Descriptions](#)

3.3.1 Signal Descriptions Overview

This section contains the pin types and signal descriptions for the 88SE9235 package.

3.3.2 Pin Type Definitions

Pin type definitions are shown in Table 3-1.

Table 3-1 Pin Type Definitions

Pin Type	Definition
I/O	Input and Output
I	Input Only
O	Output Only
A	Analog
PU	Internal Pull-Up when Input
PD	Internal Pull-Down when Input
OD	Open-Drain Pad
Ground	Ground
Power	Power

3.3.3 Signal Descriptions

This section outlines the 88SE9235 pin descriptions. All signals ending with the letter N indicate an active-low signal.

Table 3-2 PCIe Interface Signals

Signal Name	Signal Number	Type	Description
PERST_N	61	I, PU	PCI Platform Reset. Active low, indicates when the applied power is within the specified tolerance and stable.
WAKE_N	60	O, OD	PCI Wake-Up. An open-drain, active low signal that is driven low by a PCIe function to reactivate the PCIe Link hierarchy's main power rails and reference clocks. Note: For applications that support a wake-up function, connect this pin to the WAKE# signal of a PCIe card slot or system board. Connect an external pull-up resistor from the PCIe card slot or system board to the 3.3V auxiliary supply. For applications that do not support a wake-up function, keep the WAKE_N pin on the 88SE9235 open.
CLKP	58	I, A	PCIe Reference Clock of 100 MHz.
CLKN	59		
PRXP0	55	I, A	PCIe differential signals to the controller's receiver.
PRXN0	54		
PRXP1	50		
PRXN1	49		
PTXP0	52	O, A	PCIe differential signals from the controller's transmitter.
PTXN0	51		
PTXP1	47		
PTXN1	46		

Table 3-3 Serial ATA Interface Signals

Signal Name	Signal Number	Type	Description
TXN_0	33	O, A	Serial ATA Transmitter Differential Outputs.
TXP_0	34		
TXN_1	27		
TXP_1	28		
TXN_2	12		
TXP_2	13		
TXN_3	6		
TXP_3	7		
RXN_0	31	I, A	Serial ATA Receiver Differential Inputs.
RXP_0	30		
RXN_1	25		
RXP_1	24		
RXN_2	10		
RXP_2	9		
RXN_3	4		
RXP_3	3		

Table 3-4 Reference Signals

Signal Name	Signal Number	Type	Description
ISET	42	I/O, A	Reference Current for Crystal Oscillator and PLL. This pin has to be connected to an external 6.04 kΩ 1% resistor to Ground.
XTLOUT	41	O, A	Crystal Output.
XTLIN_OSC	40	I, A	Reference Clock Input. This signal can be from an oscillator, or connected to a crystal with the XTLOUT pin. The clock frequency must be 25 MHz ± 80 ppm.

Table 3-5 General Purpose I/O Signals

Signal Name	Signal Number	Type	Description
GPIO0	63	I/O, PU	General Purpose I/O.
GPIO1	69		
GPIO2	70		
GPIO3	18		
GPIO5	21		
GPIO4	20		
GPIO6	75		
GPIO7	76		

Table 3-6 SPI Flash Interface Signals

Signal Name	Signal Number	Type	Description
SPI_CLK	17	O	SPI Interface Clock.
SPI_DI	15	I, PU	Serial Data In. Connect to the serial flash device's serial data output (DO).
SPI_CS	14	O	SPI Interface Chip Select.
SPI_DO	2	O	Serial Data Out. Connect to the serial flash device's serial data input (DI).

Table 3-7 Test Mode Interface Signals

Signal Name	Signal Number	Type	Description
TP	38	I/O, A	Analog Test Point for PCIe PHY, SATA PHY, crystal oscillator, and PLL.
TST0	64	I/O	Test Pin 0.
TST1	65	I/O	Test Pin 1.
TST2	66	I/O	Test Pin 2. This pin is reserved for chip test purposes only. Keep floating.
TST3	67	I/O	Test Pin 3. This pin is reserved for chip test purposes only. Keep floating.
TST4	72	I/O	Test Pin 4. This pin is reserved for chip test purposes only. Keep floating.
TST5	73	I/O	Test Pin 5. This pin is reserved for chip test purposes only. Keep floating.
TST6	74	I/O	Test Pin 6. This pin is reserved for chip test purposes only. Keep floating.
TESTMODE	22	I, PD	Test Mode. Enables chip test modes.

Table 3-8 Power and Ground Pins

Signal Name	Signal Number	Type	Description
VAA2_0	32	Power	Analog Power.
VAA2_1	26		1.8V analog power supply for SATA PHY.
VAA2_2	11		
VAA2_3	5		
VAA1	39	Power	Analog Power. 1.8V analog power for crystal oscillator, reference current generator, and PLL.

Table 3-8 Power and Ground Pins (continued)

Signal Name	Signal Number	Type	Description
AVDD0	53	Power	Analog Power.
AVDD1	48		1.8V analog power supply for PCIe PHY.
VDDIO	16, 68	Power	I/O Power. 3.3V analog power supply for digital I/Os.
VDD	1, 19, 23, 36, 44, 62, 71	Power	1.0V Core Digital Power.
VSS	8, 29, 45, 56	Power	Ground. The main ground is the exposed die-pad (ePad) on the bottom side of the package.

Table 3-9 No Connect Signals

Signal Name	Signal Number	Type	Description
N/C	35, 37, 43, 57	N/A	No Connect.



THIS PAGE LEFT INTENTIONALLY BLANK

4 LAYOUT GUIDELINES

The chapter contains the following information:

- [Layout Guidelines Overview](#)
- [Board Schematic Example](#)
- [Layer Stack-Up](#)
- [Power Supply](#)
- [PCB Trace Routing](#)
- [Recommended Layout](#)

Refer to Chapter 3, [Package](#), for package information.



4.1 Layout Guidelines Overview

This chapter describes the system recommendations from the Marvell Semiconductor design and application engineers who work with the 88SE9235. This chapter is written for those who are designing schematics and printed circuit boards for an 88SE9235-based system. Whenever possible, the PCB designer should try to follow the suggestions provided in this chapter.

Note: The information in this chapter is intended only to provide guidelines, and is not meant to restrict the customer from exercising discretion in implementing board designs. In cases where it is deemed necessary to deviate from the guidelines, Marvell recommends that customers consult with the Marvell FAEs to ensure that the performance of the Marvell product is not compromised.

4.2 Board Schematic Example

The board schematic consists of the major interfaces of the 88SE9235 including SATA and PCIe. Figure 4-1 shows an example of board schematic.

Figure 4-1 SE9235 Example Board Schematic

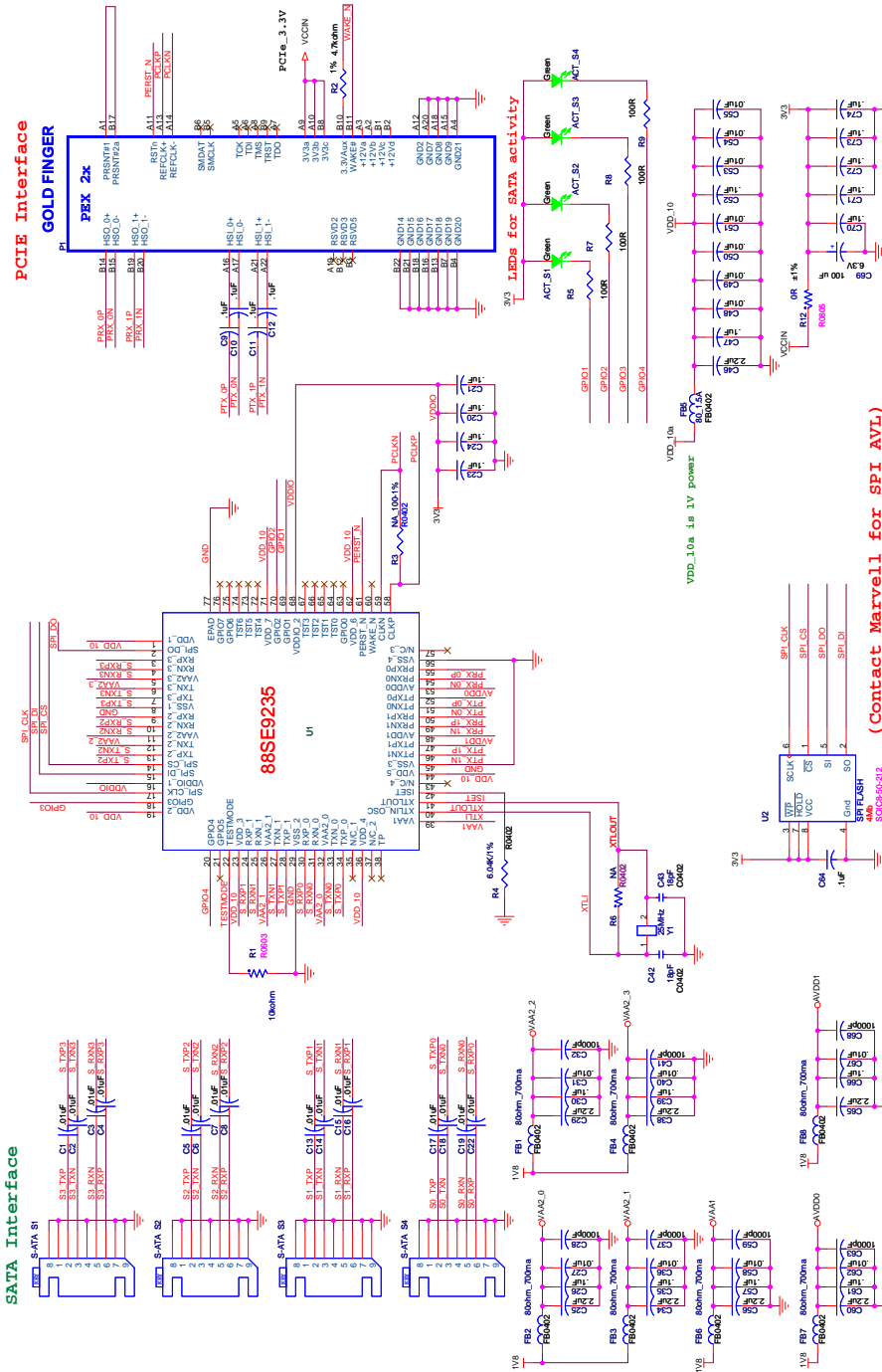



Note: This diagram is for reference only. Contact your Marvell field applications engineer for the latest schematics.

4.3 Layer Stack-Up

This section contains the following information:

- [Layer Stack-Up Overview](#)
- [Layer 1–Topside, Parts, Slow and High Speed Signal Routes, and Power Routes](#)
- [Layer 2–Solid Ground Plane](#)
- [Layer 3–Power Plane](#)
- [Layer 4–Bottom Layer, Slow and High-Speed Signal Routes, and Power Routes](#)

4.3.1 Layer Stack-Up Overview

The following layer stack up is recommended:

- [Layer 1–Topside, Parts, Slow and High Speed Signal Routes, and Power Routes](#)
- [Layer 2–Solid Ground Plane](#)
- [Layer 3–Power Plane](#)
- [Layer 4–Bottom Layer, Slow and High-Speed Signal Routes, and Power Routes](#)

5 mil traces and 5 mil spacing are the recommended minimum requirements.

4.3.2 Layer 1–Topside, Parts, Slow and High Speed Signal Routes, and Power Routes

All active parts are to be placed on the topside. Some of the differential pairs for SATA and PCIe are routed on the top layer, differential 100 ohm impedance needs to be maintained for those high speed signals.

4.3.3 Layer 2–Solid Ground Plane

A solid ground plane should be located directly below the top layer of the PCB. This layer should be a minimum distance below the top layer in order to reduce the amount of crosstalk and EMI. There should be no cutouts in the ground plane. Use of 1 ounce copper is recommended.

4.3.4 Layer 3–Power Plane

Use solid planes on layer 3 to supply power to the ICs on the PCB. Avoid narrow traces and necks on this plane.

4.3.5 Layer 4–Bottom Layer, Slow and High-Speed Signal Routes, and Power Routes

Some of the differential pairs for SATA and PCIe are routed on the top layer, differential 100Ω impedance needs to be maintained for those high speed signals. The high speed signals have the return current on the third layer, which is the power plane. Make sure there is no cut-out under the signal path.

4.4 Power Supply

This section contains the following information:

- [Power Supply Overview](#)
- [VDD Power \(1.0V\)](#)
- [Analog Power Supply \(1.8V\)](#)
- [Bias Current Resistor \(RSET\)](#)

4.4.1 Power Supply Overview

The 88SE9235 operates using the following power supplies:

- [VDD Power \(1.0V\)](#) for the digital core
- [Analog Power Supply \(1.8V\)](#)

4.4.2 VDD Power (1.0V)

All digital power pins (VDD pins) must be connected directly to a VDD plane in the power layer with short and wide traces to minimize digital power-trace inductances.

Use vias close to the VDD pins to connect to this plane and avoid using the traces on the top layer. Marvell recommends placing capacitors around the three sides of the PCB near VDD pins with the following dimensions:

- 1 μF (1 capacitor)
- 0.1 μF (2 capacitors)
- 2.2 μF (1 ceramic capacitor)

The 2.2 μF ceramic decoupling capacitor is needed to filter the lower frequency power-supply noise.

To reduce system noise, the use of high-frequency surface-mount monolithic ceramic bypass capacitors should be placed as close as possible to the channel VDD pins. At least one decoupling capacitor should be placed on each side of the IC package.

Short and wide copper traces should be used to minimize parasitic inductances. Low-value capacitors (1,000–10,000 pF) are preferable over higher values because they are more effective at higher frequencies.

4.4.3 Analog Power Supply (1.8V)

The PCIe analog supply provides power for the PCIe link's high speed serial signals. To ensure high speed link operation, use a series of bypass capacitors for the supplies. A typical capacitor value combination is 1 μF , 0.1 μF , and 2.2 μF .

4.4.4 Bias Current Resistor (RSET)

Connect a 6.04K Ω (1%) resistor between the ISET pin and the adjacent top ground plane. This resistor should lie as close as possible to the ISET pin.

4.5 PCB Trace Routing

The stack-up parameters for the reference board are shown in Table 4-1.

Table 4-1 PCB Board Stack-up Parameters

Layer	Layer Description	Copper Weight (oz)	Target Impedance ($\pm 10\%$)
1	Signal	0.5	50
2	GND	1	N/A
3	Power	1	N/A
4	Signal	0.5	50

4.6 Recommended Layout

Solid ground planes are recommended. However, special care should be taken when routing VAA and VSS pins.

The following general tips describe what should be considered when determining your stack-up and board routing. These tips are not meant to substitute for consulting with a signal-integrity expert or doing your own simulations.

Note: Specific numbers or rules-of-thumb are not used here because they might not be applicable in every situation.

- Do not split ground planes.
Keep good spacing between possible sensitive analog circuitry on your board and the digital signals to sufficiently isolate noise. A solid ground plane is necessary to provide a good return path for routing layers. Try to provide at least one ground plane adjacent to all routing layers (see Figure 4-2).
- Keep trace layers as close as possible to the adjacent ground or power planes.
This helps minimize crosstalk and improve noise control on the planes.

Figure 4-2 Trace Has At Least One Solid Plane For Return Path

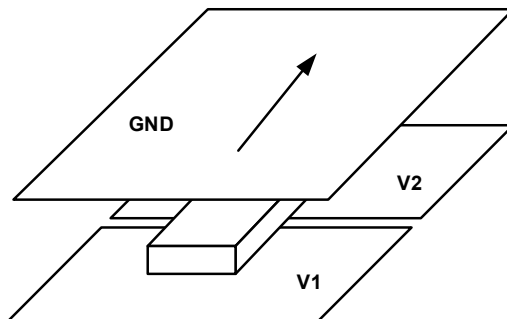

- When routing adjacent to only a power plane, do not cross splits.
Route traces only over the power plane that supplies both the driver and the load. Otherwise, provide a decoupling capacitor near the trace at the end that is not supplied by the adjacent power plane.
- Critical signals should avoid running parallel and close to or directly over a gap.
This would change the impedance of the trace.
- Separate analog powers onto opposing planes.
This helps minimize the coupling area that an analog plane has with an adjacent digital plane.
- For dual strip-line routing, traces should only cross at 90 degrees.
Avoid more than two routing layers in a row to minimize tandem crosstalk and to better control impedance.
- Planes should be evenly distributed in order to minimize warping.
- Calculating or modeling impedance should be made prior to routing.
This helps ensure that a reasonable trace thickness is used and that the desired board thickness is available. Consult with your board fabricator for accurate impedance.

- Allow good separation between fast signals to avoid crosstalk.
Crosstalk increases as the parallel traces get longer.
- When packages become smaller, route traces over a split power plane
Smaller packages force vias to become smaller, thereby reducing board thickness and layer counts, which might create the need to route traces over a split power plane. Some alternatives to provide return path for these signals are listed below.
Caution must be used when applying these techniques. Digital traces should not cross over analog planes, and vice-versa. All of these rules must be followed closely to prevent noise contamination problems that might arise due to routing over the wrong plane.
By tightly controlling the return path, control noise on the power and ground planes can be controlled.
- Place a ground layer close enough to the split power plane in order to couple enough to provide buried capacitance, such as SIG-PWR-GND (see Figure 4-3). Return signals that encounter splits in this situation simply jumps to the ground plane, over the split, and back to the other power plane. Buried capacitance provides the benefit of adding low inductance decoupling to your board. Your fabricator may charge for a special license fee and special materials. To determine the amount of capacitance your planes provide, use the following equation:
$$C = 1.249 \cdot 10^{-13} \cdot E_r \cdot L \cdot W / H$$

Where E_r is the dielectric coefficient, $L \cdot W$ represents the area of copper, and H is the separation between planes.
- Provide return-path capacitors that connect to both power planes and jumps the split. Place them close to the traces so that there is one capacitor for every four or five traces. The capacitors would then provide the return path (see Figure 4-4).
- Allow only static or slow signals on layers where they are adjacent to split planes.

Figure 4-3 shows the ground layer close to the split power plane.

Figure 4-3 Close Power and Ground Planes Provide Coupling For Good Return Path

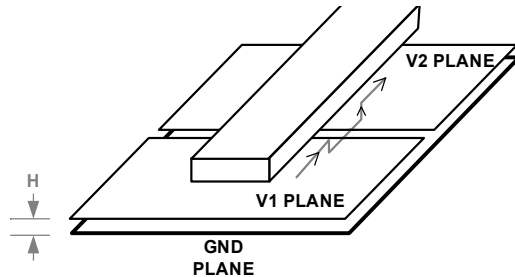
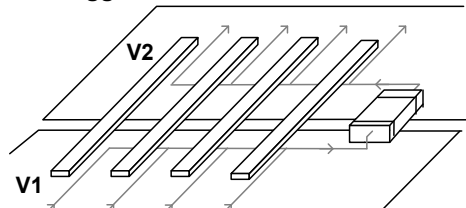

Figure 4-4 shows the thermal ground plane in relation to the return-path capacitor.

Figure 4-4 Suggested Thermal Ground Plane On Opposite Side of Chip



5 ELECTRICAL SPECIFICATIONS

This chapter contains the following information:

- [Absolute Maximum Ratings](#)
- [Recommended Operating Conditions](#)
- [Power Requirements](#)
- [DC Electrical Characteristics](#)
- [Thermal Data](#)

5.1 Absolute Maximum Ratings

Table 5-1 defines the absolute maximum ratings for the 88SE9235.

Table 5-1 Absolute Maximum Ratings*

Parameter	Symbol	Minimum	Maximum	Units
Absolute Analog Power for PCIe PHY	AVDD0 _{abs}	-0.5	1.98	V
Absolute Analog Power for PCIe PHY	AVDD1 _{abs}	-0.5	1.98	V
Absolute Analog Power for Crystal Oscillator and PLL	VAA1 _{abs}	-0.5	1.98	V
Absolute Analog Power for SATA PHY	VAA2_0 _{abs}	-0.5	1.98	V
Absolute Analog Power for SATA PHY	VAA2_1 _{abs}	-0.5	1.98	V
Absolute Digital Core Power	VDD _{abs}	-0.5	1.10	V
Absolute Digital I/O Power	VDDIO _{abs}	-0.5	3.63	V

* Estimated values are provided until characterization is complete.

5.2 Recommended Operating Conditions

Table 5-2 defines the recommended operating conditions for the 88SE9235.

Table 5-2 Recommended Operating Conditions*

Parameter	Symbol	Minimum	Type	Maximum	Units
Analog Power for PCIe PHY	AVDD0 _{op}	1.71	1.8	1.89	V
Analog Power for PCIe PHY	AVDD1 _{op}	1.71	1.8	1.89	V
Analog Power for Crystal Oscillator and PLL	VAA1 _{op}	1.71	1.8	1.89	V
Analog Power for SATA PHY	VAA2_0 _{op}	1.71	1.8	1.89	V
Analog Power for SATA PHY	VAA2_1 _{op}	1.71	1.8	1.89	V
Digital Core Power	VDD _{op}	0.95	1.0	1.05	V
Digital I/O Power	VDDIO _{op}	3.135	3.3	3.465	V
Internal Bias Reference	ISET _{op}	5.738	6.04	6.342	KΩ
Ambient Operating Temperature, Commercial	N/A	0	N/A	70	°C
Ambient Operating Temperature, Industrial	N/A	-40	N/A	85	°C
Junction Operating Temperature, Commercial	N/A	0	N/A	125	°C
Junction Operating Temperature, Industrial	N/A	-40	N/A	125	°C

* Estimated values are provided until characterization is complete.

5.3 Power Requirements

Table 5-3 defines the power requirements for the 88SE9235.

Table 5-3 Power Requirements*

Parameter	Symbol	Maximum	Units
Analog Power for PCIe PHY Transmitter	I _{AVDD0}	55	mA
Analog Power for PCI-E Phy Transmitter	I _{AVDD1}	55	mA
Analog Power for Crystal Oscillator and PLL	I _{VAA1}	10	mA
Analog Power for SATA PHY	I _{VAA2_0}	70	mA
Analog Power for SATA PHY	I _{VAA2_1}	70	mA
Digital Core Power	I _{VDD}	1500	mA
Digital I/O Power (3.3V)†	I _{VDDIO}	50	mA

* Estimated values are provided until characterization is complete.

† The digital I/O power supply can be either 3.3V or 1.8V.

5.4 DC Electrical Characteristics

Table 5-4 defines the DC electrical characteristics for the 88SE9235.

Table 5-4 DC Electrical Characteristics*

Parameter	Symbol	Test Condition	Minimum	Maximum	Units
Input Low Level Voltage	V_{IL}	N/A	-0.4	$0.25 \times V_{DDIO}$	V
Input High Level Voltage	V_{IH}	N/A	$0.8 \times V_{DDIO}$	5.5	V
Output Low Level Current	I_{OL}	$V_{PAD} = 0.4V$	5	N/A	mA
Output High Level Current	I_{OH}	$V_{PAD} = V_{DDIO} - 0.4V$	5	N/A	mA
Pull Up Strength	I_{PU}	$V_{PAD} = 0.5 \times V_{DDIO}$	10	N/A	μA
Pull Down Strength	I_{PD}	$V_{PAD} = 0.5 \times V_{DDIO}$	10	N/A	μA
Input Leakage Current	I_{LK}	$0 < V_{PAD} < V_{DDIO}$	N/A	10	μA
Input Capacitance	C_{IN}	$0 < V_{PAD} < 5.5V$	N/A	5	pF

* Estimated values are provided until characterization is complete.

5.5 Thermal Data

It is recommended to read application note *AN-63 Thermal Management for Selected Marvell® Products* (Document Number MV-S300281-00) and the *ThetaJC, ThetaJA, and Temperature Calculations White Paper*, available from Marvell, before designing a system. These documents describe the basic understanding of thermal management of integrated circuits (ICs) and guidelines to ensure optimal operating conditions for Marvell products.

Table 5-5 shows the values for the package thermal parameters for the 76-lead Quad Flat Non-Lead package (QFN 76) mounted on a 4-layer PCB. The simulation was performed according to JEDEC standards.

Table 5-5 Thermal Data for 76-pin QFN Package

Parameter	Definition	Airflow Value			
		0 m/s	1 m/s	2 m/s	3 m/s
θ_{JA}	Thermal resistance: junction to ambient	25.00 C/W	23.90 C/W	22.80 C/W	22.20 C/W
θ_{JC}	Thermal resistance: junction to case	10.10 C/W	N/A	N/A	N/A
θ_{JB}	Thermal resistance: junction to board	14.40 C/W	N/A	N/A	N/A
Ψ_{JB}	Thermal characterization parameter: junction to bottom surface center of the package.	14.30 C/W	14.20 C/W	14.10 C/W	14.00 C/W
Ψ_{JT}	Thermal characterization parameter: junction to top center	0.20 C/W	0.39 C/W	0.49 C/W	0.57 C/W

Note: In addition to the airflow requirement, a heat sink is required to assist the thermal dissipation.



Marvell Technology Group
www.marvell.com

Marvell. Moving Forward Faster