

Marvell® Alaska 88E1116R

Single-Port Gigabit Ethernet Transceiver with Integrated Passives



▶ PRODUCT OVERVIEW

The Marvell® Alaska® 88E1116R is a physical layer device containing a single Gigabit Ethernet (GbE) transceiver, and is the smallest single-port GbE PHY with integrated passives. The transceiver implements the Ethernet physical layer portion of the 1000BASE-T, 100BASE-TX, and 10BASE-T standards. Manufactured using a standard digital CMOS process, the 88E1116R contains all active circuitry required to implement the physical layer functions to transmit and receive data on standard CAT 5 unshielded twisted-pair cable.

The Alaska 88E1116R supports the Reduced Gigabit Media Independent Interface (RGMI) for direct connection to a Media Access Controller (MAC)/switch port. In addition, the 88E1116R uses advanced mixed-signal processing to perform equalization, echo and crosstalk cancellation, data recovery, and error correction at a gigabit-per-second data rate. The device achieves robust performance in noisy environments with very low power dissipation.

The 88E1116R incorporates the Marvell Virtual Cable Tester® (VCT™) feature, which uses Time Domain Reflectometry (TDR) for the remote identification of potential cable malfunctions, thus reducing equipment returns and service calls. With VCT the 88E1116R detects and reports potential cabling issues such as pair swaps, pair polarity, and excessive pair skew. The device also detects cable opens, shorts, or any impedance mismatch in the cable, and can accurately report within one meter the distance to the fault.

The 88E1116R device integrates MDI interface termination resistors into the PHY. This resistor integration facilitates board layout and reduces board cost by eliminating the need for twelve external passive components. The new Marvell calibrated resistor scheme will achieve and exceed the accuracy requirements of the IEEE 802.3 return loss specifications.

The 88E1116R features two regulators to generate all required voltages, and can run off a single 1.8V, 2.5V, or 3.3V supply. Alternatively if the regulators are not used then the 88E1116R can run off a 1.8V and 1.2V supply.

▶ BLOCK DIAGRAM

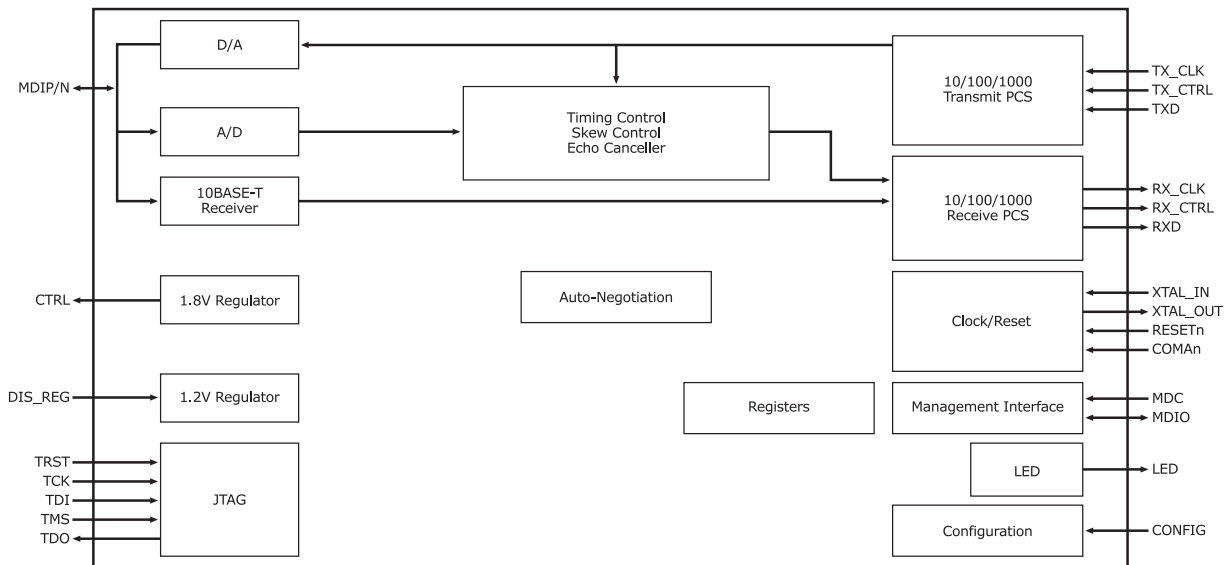

Fig 1. 88E1116R Functional Block Diagram

FEATURES	BENEFITS
<ul style="list-style-type: none"> Supports RGMII interface 	<ul style="list-style-type: none"> Significantly reduces pin count
<ul style="list-style-type: none"> Four RGMII timing modes 	<ul style="list-style-type: none"> Eliminates the need for on-board delay lines
<ul style="list-style-type: none"> Energy detect and energy detect+ low-power modes 	<ul style="list-style-type: none"> Reduces power consumption and extends battery life
<ul style="list-style-type: none"> “Downshift” mode for two-pair cable installations 	<ul style="list-style-type: none"> Preserves the Ethernet link if the line quality deteriorates
<ul style="list-style-type: none"> Automatic MDI/MDIX crossover at all speeds of operation 	<ul style="list-style-type: none"> Eases installation and reduces costs by working with both straight and cross-over cables
<ul style="list-style-type: none"> Automatic polarity correction 	<ul style="list-style-type: none"> Compensates for wiring problems
<ul style="list-style-type: none"> IEEE 802.3u compliant Auto-Negotiation 	<ul style="list-style-type: none"> Automatically configures to 10, 100, or 1000 Mbps
<ul style="list-style-type: none"> Software programmable LED modes including LED testing 	<ul style="list-style-type: none"> Allows for user-defined LED configuration
<ul style="list-style-type: none"> Supports IEEE 1149.1 JTAG 	<ul style="list-style-type: none"> Simplifies board-level testing/debugging
<ul style="list-style-type: none"> MDC/MDIO management interface 	<ul style="list-style-type: none"> Provides flexible management options
<ul style="list-style-type: none"> Virtual Cable Tester (VCT) 	<ul style="list-style-type: none"> Identifies and isolates cable faults
<ul style="list-style-type: none"> Coma mode support 	<ul style="list-style-type: none"> Provides flexible power-down functionality
<ul style="list-style-type: none"> I/O pads can be supplied with 1.8V, 2.5V, or 3.3V 	<ul style="list-style-type: none"> Allows for flexibility in I/O connections
<ul style="list-style-type: none"> Two regulators generate all required voltages. Regulator can be supplied with 1.8V, 2.5V or 3.3V 	<ul style="list-style-type: none"> Eliminates the need for an external regulator

APPLICATIONS

The Alaska 88E116R is Marvell’s lowest power, single-port Gigabit Ethernet transceiver. Offered in a QFN64 measuring only 9×9mm on each side, the 88E116R is the smallest package footprint Gigabit Ethernet transceiver in the industry. The 88E116R is ideal for GbE networking applications such as high-performance printers, game consoles, LAN on motherboards (LOM), media vaults, and other multi-media applications requiring a connection over standard Cat-5 cable.

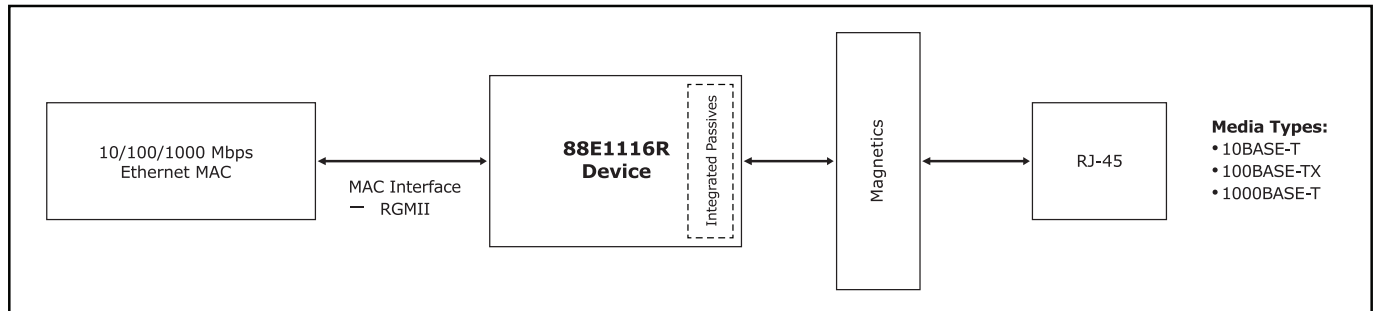

Fig 2. 88E116R System Diagram

THE MARVELL ADVANTAGE: Marvell products come with complete reference designs which include board layout designs, software, manufacturing diagnostic tools, documentation, and other items to assist customers with product evaluation and production. Marvell’s worldwide field application engineers collaborate closely with end customers to develop and deliver new leading-edge products for quick time-to-market. Marvell utilizes world-leading semiconductor foundry and packaging services to reliably deliver high-volume and low-cost total solutions.

ABOUT MARVELL: Marvell is the leader in storage, communications and consumer silicon solutions. Marvell’s diverse product portfolio includes switching, transceiver, communications controller, processors, wireless, power management and storage solutions that power the entire communications infrastructure, including enterprise, metro, home, and storage networking. For more information, visit our website at www.marvell.com.



Marvell Semiconductor, Inc.
5488 Marvell Lane
Santa Clara, CA 95054
Phone 408.222.2500
www.marvell.com

Copyright © 2007, Marvell International Ltd. All rights reserved. Marvell, the Marvell logo, Moving Forward Faster, Alaska, Datacom Systems on Silicon, Fastwriter, Libertas, Link Street, NetGX, PHYAdvantage, Prestera, Raising The Technology Bar, The Technology Within, Virtual Cable Tester, and Yukon are registered trademarks of Marvell. Marvell Makes It All Possible, Ants, AnyVoltage, Discovery, DSP Switcher, Feroceon, GalNet, GalTis, Horizon, RADLAN, UniMAC, and VCT are trademarks of Marvell. All other trademarks are the property of their respective owners