

# Marvell® QLogic® QME2742-DEL

Dual-Port, 32GFC Fibre Channel Mezzanine Adapter

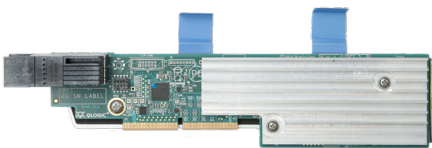

- The latest and most advanced 32GFC, dual-port mezzanine Marvell QLogic adapter
- Up to 1.3 million IOPS fuel high performance in AFA and high-density virtualized environments
- Enhanced reliability, diagnostics, and accelerated deployment powered by Marvell StorFusion technology
- Improve scale out NVMe efficiencies by delivering concurrent support for FCP and FC-NVMe™
- Port isolation design offers deterministic and scalable performance on each port

The 32Gb Fibre Channel (GFC) QME2742-DEL is the industry's first 32GFC dual-port mezzanine adapter, created for the Dell® modular chassis platform. Designed with full hardware offloads, the QME2742-DEL boasts industry-leading native Fibre Channel (FC) performance with extremely low CPU usage.

## 32GFC Technology

Marvell 32GFC mezzanine solution offers higher per-port performance (up to 650K IOPS) with lower power consumption. In addition, Marvell StorFusion™ technology delivers streamlined provisioning, guaranteed QoS, and improved resiliency with built-in forward error correction (FEC). These features address the needs of IT organizations that require reliability, integrated management, and guaranteed network performance.

Marvell QLogic FC technology resolves data center complexities by enabling a storage network infrastructure that supports powerful virtualization features, application-aware services, and simplified management. The QME2742-DEL mezzanine adapter provides advanced storage networking features capable of supporting the most demanding virtualized and private cloud environments. This adapter fully leverages the capabilities of high-performance 32GFC, all-flash arrays (AFAs), and demanding enterprise applications. Powerful management tools automate and simplify SAN provisioning to help reduce cost and complexity, while the unmatched 32GFC line rate performance eliminates potential I/O bottlenecks in today's powerful multiprocessor, multicore servers.

## Superior Performance

The QME2742-DEL mezzanine adapter can accelerate mission-critical enterprise applications by delivering up to 1.3 million IOPS for physical, virtual, and private cloud environments. Marvell QLogic adapters deliver the best storage application performance in both virtualized and non-virtualized environments with up to 12,800MBps of aggregate throughput.

## Virtualization Optimized

The Marvell QLogic QME2742-DEL mezzanine adapter supports standards-based virtualization features. Under VMware® ESXi 6.7, 7.x, and later, I/O requests and responses can be tagged with the virtual machine-ID (VM-ID) of the appropriate virtual machine, providing end-to-end visibility at the VM level. Support for N\_Port ID virtualization (NPIV) enables a single FC adapter port to provide multiple virtual ports for increased network scalability. Standard class-specific control (CS\_CTL)-based QoS

technology per NPIV port allows bandwidth controls and guarantee per VM. In addition, the 32GFC line rate per physical port delivers unmatched storage performance to maximize the quantity of VMs per physical server.

## Marvell StorFusion Technology

Marvell QLogic 32GFC mezzanine adapters, powered by StorFusion technology, include advanced capabilities that are enabled when deployed with supported Brocade® switches. By combining these industry-leading solutions, SAN administrators can take advantage of enhanced features that improve availability, accelerate deployment, and increase network performance. StorFusion solves the top issues for SAN administrators worldwide.

### Improved TCO and Reliability

Marvell technology includes the read diagnostic parameters (RDP) feature, which provides detailed port, media, and optics diagnostics while the link is in service. From any point in the fabric, an administrator can use RDP to easily access diagnostic information, thereby enabling identification of link-related errors and degrading conditions on any N\_Port-to-F\_Port link.

The extensive suite of diagnostic tools maximizes uptime and performance, allowing organizations to address problems before they impact operations.

### Rapid Server Deployment and Orchestration

StorFusion technology includes fabric pre-provisioning services that enable servers to be quickly deployed, replaced, and moved across the SAN. By leveraging fabric-assigned port world wide name (FA-WWN) and fabric-based boot LUN discovery (F-BLD) capabilities, the creation of zones, LUNs, SAN-based boot images, and other services can be completed before the servers arrive on site—eliminating time-consuming, manual tasks that typically delay server deployment.

### Performance SLA Enforcement with VM-level QoS

Network performance can be dramatically improved by implementing the industry-standard class-specific control (CS\_CTL)-based frame prioritization QoS, which helps alleviate network congestion. When Dell adapters with Marvell StorFusion technology are connected to supported SAN fabrics, traffic is classified as it arrives at the switch, and is then processed on the basis of configured priorities. Traffic can be prioritized for delivery or subjected to limited delivery options. As a result, mission-critical workloads can be assigned a higher priority than less time-sensitive network traffic for optimized performance.

### Higher Resiliency and Performance with Automatic Error Recovery

FEC is automatically used at 32GFC as required by the *Fibre Channel Specification* to improve performance and link integrity. FEC automatically detects and automatically recovers from bit errors, which results in higher availability and performance.

Automatic buffer-to-buffer credit recovery (BB-CR) helps overcome performance degradation, congestion, and link resets caused by buffer credit loss, especially on longer-distance and high-loss fiber connections.

## Simplified Management

The Marvell unified CLI management application, QConvergeConsole® (QCC), provides single-pane-of-glass management across generations of Marvell QLogic FC adapters. In addition, Marvell supports all major APIs for deployment flexibility and integration with third-party management tools, including VMware vCenter™ and Brocade Network Advisor.

## High Availability and Reliability

Marvell QLogic 32GFC mezzanine adapters continue the tradition of providing complete port-level isolation across the FC controller architecture. This architecture, unlike other vendor solutions, provides independent function, transmit and receive buffers, an on-chip CPU, DMA channels, and a firmware image for each port. These features enable complete port-level isolation, prevent errors and firmware crashes from propagating across both ports, and provide predictable and scalable performance across both ports. The Marvell architecture delivers ultimate reliability to meet the needs of mission-critical enterprise applications, with lower power and fewer CPU cycles, all while maintaining peak performance.

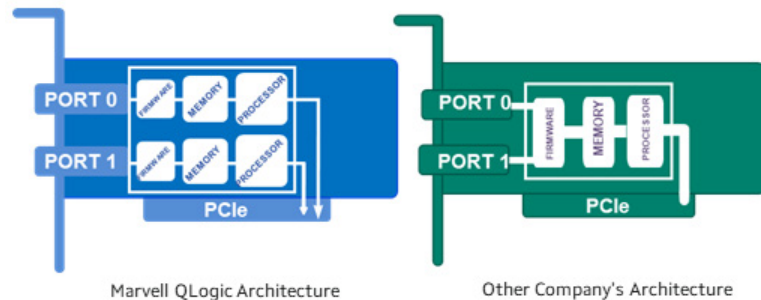

Figure 1. Port Isolation

In addition, overlapping protection domains (OPDs) ensure the highest level of reliability as data moves to and from the PCI® bus and FC network.

The QME2742-DEL mezzanine adapter also provides end-to-end data integrity with support for T10 Protection Information (T10 PI), which prevents the risk of silent data corruption in environments running Oracle® Linux® with the Unbreakable Enterprise Kernel.

## Leadership, Confidence, and Trust

The Marvell QLogic QME2742-DEL mezzanine adapters are compatible with the same FC software driver stack that has been tested and validated across all major hardware platforms, as well as all major hypervisors and operating systems.

Marvell technology makes it the undisputed leader in FC adapters, with over 20 years of experience, more than 20 million ports shipped, and multiple generations of FC products that have been the leading choice of Marvell customers. Marvell owns the most established, proven FC stack in the industry, with more FC ports shipped than any other vendor.

## Host Bus Interface Specifications

### Bus Interface

- QME2742-DEL: PCIe® 3.0 x8

### Host Interrupts

- INTx and MSI-X

### Compliance

- *PCI Express Base Specification, Rev. 3.1*
- *PCI Express Card Electromechanical Specification, Rev. 3.0*
- *PCI Bus Power Management Interface Specification, Rev. 1.2*

## Fibre Channel Specifications

### Throughput

- 32GFC line rate per port (maximum)

### Logins

- Support for 2,048 concurrent logins and 2,048 active exchanges per port

### Port Virtualization

- NPIV

### Compliance

- *Fibre Channel Physical Interface 5 (FC-PI5)*
- *Fibre Channel Physical Interface 6 (FC-PI6)*
- *Fibre Channel Tape (FC-TAPE) Profile*
- *SCSI Fibre Channel Protocol-2 (FCP-2)*
- *SCSI-3 Fibre Channel Protocol (SCSI-FCP)*
- *Second Generation Fibre Channel Generic Services (FC-GS-2)*
- *Third Generation Fibre Channel Generic Services (FC-GS-3)*

## Tools and Utilities

### Management Tools and Device Utilities

- QConvergeConsole integrated network management utility (CLI) for Linux and Windows

### Boot Support

- BIOS
- Unified Extensible Firmware Interface (UEFI)

### APIs

- SNIA HBA API V2
- SMI-S

### Operating Systems

- For the latest applicable OS information, see [support.dell.com](http://support.dell.com)

## End-to-End Provisioning and Management Features

*The following features require a supported Brocade switch.*

### Performance

- QoS CS\_CTL
- FEC
- Buffer-to-buffer credit recovery (BB-CR): automatic buffer credit loss detection and recovery

### Diagnostics

- RDP

### Deployment and Management

- FA-WWN
- F-BLD
- FC Ping
- FC Traceroute
- Fabric device management interface (FDMI) enhancements
- VM-ID

## Physical Specifications

### Ports

- QME2742-DEL: dual-port, 32GFC

### Form Factor

- Mezzanine adapter (Dell Blade Servers: MX740c and MX840c)

## Environment and Equipment Specifications

### Temperature

- Operating: 0°C to 55°C (32°F to 131°F)
- Storage: -20°C to 70°C (-4°F to 158°F)

### Humidity

- Operating: 10% to 90%
- Storage: 5% to 95%

## Agency Approvals—Safety

### US and Canada

- UL 60950-1
- CSA C22.2

### Europe

- TUV EN60950-1
- TUV IEC 60950-1
- EN IEC 62368 2nd, 3rd Edition
- CB certified

## Agency Approvals—EMI and EMC (Class A)

### US and Canada

- FCC Rules, CFR Title 47, Part 15, Subpart Class A
- Industry Canada, ICES-003: Class A

### Europe

- EN55032
- EN55035
- EN61000-3-2
- EN61000-3-3

### Japan

- VCCI: Class A

### New Zealand and Australia

- AS/NZS: Class A

### Korea

- KC-RRR Class A

### UK

- UKCA
- BS DoC

## Ordering Information

### QME2742-DEL

- With server, order SKU# 544-BBCP
- Without server, order SKU# 540-BCJD



To deliver the data infrastructure technology that connects the world, we're building solutions on the most powerful foundation: our partnerships with our customers. Trusted by the world's leading technology companies for 25 years, we move, store, process and secure the world's data with semiconductor solutions designed for our customers' current needs and future ambitions. Through a process of deep collaboration and transparency, we're ultimately changing the way tomorrow's enterprise, cloud, automotive, and carrier architectures transform—for the better.

Copyright © 2021 Marvell. All rights reserved. Marvell and the Marvell logo are trademarks of Marvell or its affiliates. Please visit [www.marvell.com](http://www.marvell.com) for a complete list of Marvell trademarks. Other names and brands may be claimed as the property of others.