

Improved Performance and QoS for QLogic Enhanced Gen 5 (16Gb) and Gen 6 (32Gb) Fibre Channel Adapters

Leveraging Advanced Brocade Fabric Vision Capabilities with QLogic StorFusion



Meet and exceed service-level agreements (SLAs) with end-to-end SAN traffic prioritization and network resiliency

- Alleviate network congestion by enabling administrators to prioritize traffic with enhanced CS_CTL-based QoS.
- Improve performance and link integrity with FEC to support higher end-to-end data rates by auto recovering from transmission errors.
- Assign critical workloads the highest priority for optimal performance across the SAN.
- Easily create, modify, and prioritize virtual ports and end-to-end SAN traffic with QoS and NPIV technology.
- Rapidly scale virtual environments and increase performance without compromising SLAs.
- Improved performance and resiliency with automatic BB-CR.

Enterprise organizations deploy a wide range of technology to meet their business needs. Administrators understand that one size does not fit all, so they offer tiered solutions based on required performance, availability, and other factors.

Virtual environments often contain thousands of virtual machines (VMs) that run a variety of workloads, ranging from high to low priority. In addition, deploying solid state drives (SSDs) – also called flash storage – has created a new, high-performance storage tier. By eliminating I/O bottlenecks that plague some traditional spinning-disk solutions, flash storage is a popular platform for demanding applications. To meet the needs of high-performance virtual, physical, and cloud environments, Storage Area Network (SAN) administrators must reduce or eliminate network bottlenecks and improve network resiliency.

JOINT QLOGIC® AND BROCADE® SOLUTION

QLogic StorFusion™ is a new suite of QLogic Enhanced Gen 5 (16Gb) FC and Gen 6 (32Gb) Fibre Channel (FC) features from Cavium™ leveraging Brocade's Gen 5 FC and Gen 6 FC Fabric Vision™ designed to address the needs of IT organizations that require reliability, security, and guaranteed network performance. Leveraging the quality of service (QoS) capabilities provided by StorFusion enables SAN administrators to assign mission-critical workloads a higher priority than less time-sensitive storage traffic. Prioritizing SAN traffic can optimize performance between the host and target.

Enhanced Gen 5 FC and Gen 6 FC adapters offer this enhanced capability via StorFusion with support for industry-standard class-specific control (CS_CTL)-based frame prioritization QoS. This leverages Brocade Fabric Vision capabilities in conjunction with Brocade Gen 5 FC and Gen 6 FC switches and target arrays that support CS_CTL-based QoS. When connected to Brocade Gen 5 FC and Gen 6 FC SAN fabrics, traffic is classified as it arrives at the switch, and then processed on the basis of configured priorities. Traffic can be dropped, prioritized for delivery, or subjected to limited delivery options. Intuitive, single-pane-of-glass management is available via Brocade Network Advisor. As a result, critical applications and workloads can enjoy fast, reliable SAN performance to meet business and service level objectives.

PRIORITIZE VM TRAFFIC

Integrated management capabilities make it easy for administrators to manage virtualized data centers and storage networks. QLogic adapters from Cavium also support N_Port ID Virtualization (NPIV) technology, which allows a single FC adapter port to provide multiple virtual ports that can be assigned to individual VMs, increasing network scalability and flexibility. Working in conjunction with NPIV, support for CS_CTL-based QoS enables administrators to prioritize storage traffic to meet the needs of critical VM workloads. This results in optimized end-to-end SAN performance.

Fully integrated with Cavium's powerful, single-pane-of-glass management application—QConvergeConsole® (QCC)—administrators can easily set up NPIV-based virtual ports and prioritize network traffic via QoS in Microsoft® Windows Server® 2012 Hyper-V and VMware vSphere 5.x and 6.x environments. Additional key capabilities include:

- **Extended Virtualization** – VMs running on physical servers are assigned to their own virtual FC port, each with their own QoS, security, and management policies.
- **Lower Total Cost of Ownership (TCO)** – Instead of purchasing dedicated Host Bus Adapters (HBAs) to guarantee bandwidth to each workload, a single physical HBA port with NPIV and QoS technology can balance the diverse needs of multiple workloads.
- **Guaranteed QoS** – Incoming and outgoing I/O is prioritized by the HBA based on user-defined priorities.

- **Granular Controls** – Fine-grained QoS levels managed dynamically from a single-pane-of-glass management application delivers the highest levels of service
- **Enhanced Traffic Management** – Prioritized FC frames are routed end-to-end, depending on user-defined settings.

Using the CS_CTL field enables QoS at the packet level. This allows an administrator to prioritize frames between a host and target depending on the value of the CS_CTL field in the FC frame header. These capabilities work in conjunction with supported Brocade Gen 5 and Gen 6 FC switches and storage arrays.

As a result, administrators can assign SAN traffic a specific priority (high, medium, or low) depending on the workload (Figure 1).

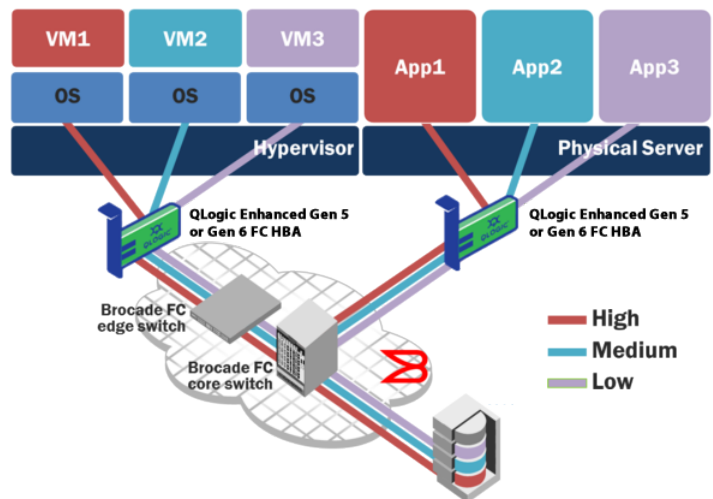

Figure 1. Optimizing SAN Traffic from the Target to the Host Enables Administrators to Prioritize Workloads for High Performance and Rapidly Scale Virtual Environments without Compromising SLAs

HIGHER RESILIENCY AND PERFORMANCE WITH AUTOMATIC ERROR RECOVERY

Forward error correction (FEC) is a new Enhanced Gen 5 FC and Gen 6 FC feature that improves performance and link integrity to support higher end-to-end data rates by automatically recovering from transmission errors. FEC automatically detects and recovers from bit errors, which results in higher availability and performance.

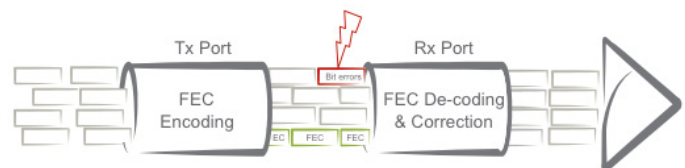

Figure 2. FEC Helps Minimize or Avoid Data Stream Errors that Lead to Application Performance Degradation or Outages

ENHANCED PERFORMANCE WITH AUTOMATIC RECOVERY FROM CREDIT LOSS (BB-CR)

To prevent an FC host or storage device from being overwhelmed with frames beyond its receive capability, the protocols employ a credit-based mechanism where the sender and receiver exchange capabilities and keep track of how many frames were sent with an acknowledgment received—called the buffer-to-buffer credit mechanism.

In certain situations like long distance and lossy links, the FC SAN can suffer from loss of buffer credits that can cause I/Os to stall and link resets to occur, degrading performance. QLogic Enhanced Gen 5 FC and Gen 6 FC adapters operating at 16Gb FC speeds and higher implement and automatically use a buffer-to-buffer credit recovery (BB-CR) mechanism that detects the loss of buffer credits due to frame loss or corruption and automatically recovers buffer credits without disrupting any applications.

TECHNOLOGY REQUIREMENTS

Enabling CS_CTL-based QoS capabilities with QLogic StorFusion requires:

- Servers with one or more QLogic 2690 Series Enhanced Gen 5 FC and 2700 Series Gen 6 FC Adapters
- Brocade Gen 5 FC or Gen 6 FC switch with FOS v7.3.0a or higher and CS_CTL-based QoS enabled
- Storage/target arrays that support CS_CTL-based QoS

Enabling FEC capabilities with QLogic StorFusion requires:

- Servers with one or more QLogic 2690 Series Enhanced Gen 5 FC and 2700 Series Gen 6 FC Adapters
- Brocade Gen 5 or Gen 6 FC switch with FOS 7.4x or higher and CS_CTL-based QoS enabled
- Storage/target arrays that support CS_CTL-based QoS

Enabling BB-CR capabilities with QLogic StorFusion requires:

- Servers with one or more QLogic 2690 Series Enhanced Gen 5 FC and 2700 Series Gen 6 FC Adapters
- Brocade Gen 5 FC or Gen 6 FC switch with FOS version 7.4.x and higher
- BB-CR is enabled by default in new factory programmed adapters, and can be enabled on older QLogic 2690 Series Enhanced Gen 5 FC and 2700 Series Gen 6 FC Adapters

ABOUT CAVIUM

Cavium, Inc. (NASDAQ: CAVM), offers a broad portfolio of infrastructure solutions for compute, security, storage, switching, connectivity and baseband processing. Cavium's highly integrated multi-core SoC products deliver software compatible solutions across low to high performance points enabling secure and intelligent functionality in Enterprise, Data Center and Service Provider Equipment. Cavium processors and solutions are supported by an extensive ecosystem of operating systems, tools, application stacks, hardware reference designs and other products. Cavium is headquartered in San Jose, CA with design centers in California, Massachusetts, India, Israel, China and Taiwan.



Follow us:      

Corporate Headquarters Cavium, Inc. 2315 N. First Street San Jose, CA 95131 408-943-7100

International Offices UK | Ireland | Germany | France | India | Japan | China | Hong Kong | Singapore | Taiwan | Israel

Copyright © 2015 - 2017 Cavium, Inc. All rights reserved worldwide. QLogic LLC (formerly QLogic Corporation) is a wholly owned subsidiary of Cavium, Inc. Cavium, QLogic, QConvergeConsole, and StorFusion are registered trademarks or trademarks of Cavium Inc., registered in the United States and other countries. All other brand and product names are registered trademarks or trademarks of their respective owners.

This document is provided for informational purposes only and may contain errors. Cavium reserves the right, without notice, to make changes to this document or in product design or specifications. Cavium disclaims any warranty of any kind, expressed or implied, and does not guarantee that any results or performance described in the document will be achieved by you. All statements regarding Cavium's future direction and intent are subject to change or withdrawal without notice and represent goals and objectives only.